

Knight Nite

Senior Design Group 6

Department of Electrical Engineering & Computer Science

University of Central Florida

Dr. Samuel Richie

Mark Hughes Atkins

Marcus Hobbs

Hieu Pham

Ahkeim Pierre

1. Executive Summary	1
2. Project Description	1
2.1 Motivation	1
2.2 Goals and Objectives.....	3
2.3 Overall Requirements	3
2.4 Hardware Requirements.....	5
2.4.1 Vital Unit Requirements.....	5
2.4.2 Audio Unit Requirements	6
2.4.3 Microcontroller Unit Requirements	7
2.4.4 Light Unit Requirements.....	8
2.4.5Cooling Unit Requirements.....	9
2.5 Software Requirements	10
2.5.1 Visualization and Control Unit (VCU) Requirements	11
3. Division of Labor.....	12
4. Research	16
4.1 Sleep Stages.....	16
4.2 Sleep Disorders	17
4.4 Existing Projects/Products	18
4.4.1 Knight Time	18
4.4.2 Knight's Wireless Baby Monitor	19
4.4.3 Withings Aura Sleep System.....	19
4.4.4 SleepRate.....	20
5. Subsystem Components.....	20
5.1 Heart Rate	21
5.2 Temperature.....	21
5.3 Motion	26
5.4 Audio	27
5.5 Lighting	29
5.5.1 Light Detection.....	29
5.5.2 Photodetector Voltage	30
5.5.3 Light Generation	30
5.5.4 LEDs.....	31

5.5.5	LED Strips	31
5.5.6	Surface Mount vs Through-Hole	32
5.5.7	LED Orientation	32
5.5.8	LED Brightness.....	33
5.5.9	Control Signal	33
5.5.10	Amplification.....	34
5.5.11	Switching Power to LED	34
5.5.12	Color of Light.....	35
5.5.13	Safety Concerns	36
5.5.14	Power Source	36
5.5.15	LED Housing.....	37
5.5.16	Photodetectors.....	38
5.6	Cooling	39
5.7	Microcontrollers.....	40
6.	User Interface	46
6.1	Android.....	47
6.2	iOS.....	48
6.3	Window 10 Mobile.....	49
6.4	Data Visualization.....	50
6.4.1	AndroidPlot.....	51
6.4.2	MPAndroid Chart.....	51
6.4.3	GraphView.....	52
7.	Power	53
7.1	Power Configuration	54
7.1.1	AC Power.....	55
7.1.2	Fly Back Controllers.....	56
7.1.3	DC Power	58
7.1.4	Buck Converters.....	58
7.1.5	Types of Batteries	60
8.	ABET Standards & Constraints.....	61
8.1	Design Constraints.....	62
8.1.1	Economic.....	62
8.1.2	Ethical.....	62

8.1.3	Health and Safety.....	62
8.1.4	Timing.....	63
9.	Hardware and Software Design	64
9.1	Emergency System.....	67
9.2	Vital Systems	68
9.3	Audio System.....	71
9.3.1	Microphone.....	72
9.3.2	Buzzer	74
9.4	Lighting System.....	77
9.4.1	LEDs.....	77
9.5	Cooling System.....	78
9.5.1	Pump.....	79
9.5.2	Fluid.....	79
9.5.3	Fluid Lines	79
9.5.4	Power	79
9.6	Software Design	88
10.	System Implementation.....	95
10.1	Motion Sensor.....	95
10.2	Temperature Sensor	98
10.3	Heart Rate Sensor	98
10.4	Audio Sensor.....	99
10.5	Lighting	100
10.6	Printed Circuit Board.....	101
11.	Testing	103
11.1	Vital Systems	104
11.2	Audio System.....	106
11.3	Lighting Systems	106
11.3.1	Photodetector Testing	106
11.3.2	LED Testing.....	108
11.4	Cooling System.....	108
11.5	Power Unit Testing.....	109
11.6	System Integration Testing	110
11.7	User Interface	110

11.8	Complete Integration	112
12.	Milestones	113
12.1	Budget and Financing.....	115
12.2	Design Summary	120
13.	Appendix.....	122
13.1	Permission to use content.....	122
14.	Bibliography	123

1. Executive Summary

Sleep is one of the most vital parts of the day for most people around the world. Over the years, we have seen the people close to us battling sleep disorders caused from stress, studying for final exams, and dealing with the reality of financial responsibility. Other people are diagnosed with sleep disorders like insomnia and sleep apnea. There are many products that have been manufactured to measure one or two of the user vitals or provide an alarm to wake the user up in the morning.

However, the problem with existing products is that very few of them contain features that provide sleep aid for people with sleep problems such as insomnia. Knight Nite is designed to provide a real-time solution for sleep disorders that plague those closest to us. Insomnia, sleep apnea, and sleep restless legs syndrome are a few disorders we plan to treat with our product.

Knight Nite will prompt the user to answer questions about their typical sleeping patterns, and the information collected from the user will be used to get a baseline of their unique symptoms. Furthermore, Knight Nite will monitor the ambient light in their sleeping environment as well as the ambient noises. Observing the light and noise allow Knight Nite to paint a picture as to what was going on around the user during the night. Vitals such as heart rate, body temperature, and breathing will also be monitored to regulate the timing of the different treatments we plan to implement with our product.

The treatments featured by our product are a white noise generator, a cooling unit to regulate the temperature of the frontal lobe, and a lighting unit to wake the user up at the appropriate time. Knight Nite utilizes a microcontroller that will synthesize all the data gathered from the user survey and sensors to provide the most viable treatment to help the user sleep more sound. The sleep data will be displayed on a mobile app to make the user aware of the different factors affecting their sleep on a daily basis. We want KnightNite to become *the* designated go-to sleep solution for users who want to get the best rest possible.

2. Project Description

2.1 Motivation

Sleep deprivation and sleep disorders severely impact a person's physical and mental abilities, overall health, and quality of life. Furthermore, sleep loss can be shown to directly and significantly affect the national economy. Sleep deprived employees are not as efficient and can pose a safety risk in jobs requiring operation of heavy machinery for example. Reports from European national driving authorities indicate drowsy and fatigued driving represents 10 to 30 percent of all automobile crashes. The National Highway Traffic Safety

Administration estimates 100,000 crashes are the direct result of fatigue every year [16]. Public health authorities estimate many billions of dollars are spent on doctor visits, hospitalization, and medicine. The general conclusion of many medical professionals and economy analysts is sleep deprivation and sleep disorders have high economic costs and severely affect the quality of health of individuals.

The medical community frequently prescribes powerful medications to combat insomnia and sleep disorders. A Center for Disease Control report on sleep aid use among adults indicates that approximately nine million Americans take prescription pills for sleep [1]. The most affected group is the elderly with an estimated seven percent of all adults aged 80 and older depending on prescription medication for sleep. The use of prescription medication for sleep frequently have severe side effects, including physical dependency and cognitive impairment, affecting the mental and physical quality of life of users. However, the medical community and sleep deprived population pursue any means including dependency on drugs to get a good night's sleep.

There are many sleep diagnostic and sleep aid devices on the consumer market. For example, there are medical grade diagnostic systems intended to detect sleep disorders such as sleep apnea and restless leg syndrome. Additionally, there is the Continuous Positive Airway Pressure (CPAP) intended to treat sleep apnea. In general, medical grade devices are expensive and only available by prescription from a medical professional. Cheaper alternatives exist in the form of smartphone applications and inexpensive devices. The simplest devices aim to provide the user a record of sleep activity and wake her in the lightest stage of sleep. However, there are no devices on the market that can claim to provide an active solution to the most common sleep disorder insomnia.

The Knight Nite system intends to provide sleep diagnostics and an active sleep aid. The active component of the system will aid the average person with insomnia and other sleep disorders get to sleep in a shorter time and stay asleep for longer. Furthermore, the system will record the user's sleep activity with the aim of providing an indicator of common sleep disorders like sleep apnea. The user will be equipped with sensors packages in a small form factor. A record of sleep activity and control of the system will be provided in an easy to use smartphone application.

The motivation behind this project came from the lack of products on the market that actually aid someone with sleep disorders. There is a myriad of sleep products that monitor and display the behavior of the user's sleep patterns. However, they only do just that, monitor and display. Therefore, Knight Nite will implement sleep monitoring and use data from monitoring sleep patterns to aid the user.

2.2 Goals and Objectives

The objective of this project is to build a reliable sleep monitor system that can be used to help treat users with sleep disorders. Our goal is that the system will monitor and apply basic applications to help the user sleep. The system will monitor respiration, and body heat and compare the outputs against thresholds. If the thresholds are exceeded a treatment protocol will be enabled.

The monitoring system will be placed on the user's head, with shades covering their eyes. There will be a vital sensor to measure user's temperature and pulse, an audio sensor monitoring the user's respiration comparing the outputs against known parameters. The unit will be ready to implement a treatment protocol upon any abnormality. Furthermore, the objective build a reliable sleep monitor system that can be used to help treat users with sleep disorders.

Considering the user, the device will be simple enough to the extent where the user will be able to use all of the functions and interpret the data through the user interface without being confused. Although there will be many complex components within Knight Nite, the end goal is to produce an effective and simple product that can aid users with sleep disorders to fall asleep faster and stay asleep longer.

There are many different ways to detect the user's position, body temperature, sounds and movement and this system utilizes only three the temperature, audio, and motion. Infrared detectors will be used for detecting body temperature and movement, while a microphone sensor will be used to detect sounds. Since this device is to be placed on the user's head thus safety is extremely important. The unit must be tested for all-around physical endurance. It must be tested for possible fire hazards and electrical short circuits which might shock to the user.

If the device were to malfunction the user must be able to easily repair the system, or purchase another piece of the system without incurring great cost. Individual pieces of the system must be available for purchase in nearby stores not to inconvenience the user as such inconvenience might leave the user in a sleepless state and could result in its demise.

2.3 Overall Requirements

The overall requirements of Knight Nite are given in Table 1. These are the preliminary requirements to the design of Knight Nite as they may change further down the design process. Most of these requirements will not change because they will be specific guidelines to the project in order to keep a set standard to insure the functionality and implementation of Knight Nite.

Table 1 Overall Requirements of Major Subsystems

Light System	Monitor ambient light
	Powered by 100-120 Volts
	Utilize LED lamps
	Monitor the light spectrum in the surrounding environment
	Provide various brightness levels to wake up the user
Auditory System	Monitor breathing intervals
	Generate sounds varying in frequency
	Generate sounds varying in intensity
	Utilize feedback based on the user's vital signs to implement alarm
Cooling System	Have a fluid system
	Reservoir and pump with liquid to cool the forehead
	Separate the reservoir away from the user
	Ability to stay on for an 8 hour sleep cycle
	Use low power for efficiency
Controller	Process data via survey from user
	Process data from sensors
	Control the cooling system
	Corded power from DC power supply

	Must meet support of all sensors and control algorithms
Data Processing	Display information during sleep cycle about the user
	Show graphs/charts/percentages
	Offers future suggestions for the user
	User interface is easy to use
	Provide survey and control of the device

2.4 Hardware Requirements

2.4.1 Vital Unit Requirements

The hardware for the vital unit consists of multiple sensors to monitor the behavior of the user during sleep. The requirements for the hardware are important in order to obtain accurate measurements and readings as well as the sensors being easy to work with. For this project, skin temperature, heart rate, and movement will be measured. There are an abundant amount of sensors and ways to measure these parameters therefore the sensors that are chosen will have to be narrowed down to which are the most cost efficient, accurate, and reliable to engineer into an entire project.

The sensor for skin temperature needs to be small enough in order to integrate it within the head device of the system. For example, the sensor cannot be too large where it becomes bulky and makes the head unit cumbersome to wear. Therefore, it should be rather compact in order for the user to have minimal notice and attention to the actual sensor. Furthermore, since the sensor is in close proximity with the cooling pad, there is a possibility that the condensation from the pad will leak onto the user or sensor itself. Therefore, the sensor needs to be positioned in a way where it is taking accurate readings from the user's forehead while remaining dry. Table 2 shows the vital system requirements that are essential to the performance of the subsystem.

Table 2 Vital System Requirements

Vital System Requirements	Has its own microcontroller system and PCB
	Heart Rate Sensor outputs digital signal
	Temperature sensor outputs digital signal
	Motion sensor outputs digital signal
	Uses low power for efficiency
	Stays on for an 8 hour sleep cycle
	Sensors powered by USB from the MCU
	Has an emergency wake up feature

2.4.2 Audio Unit Requirements

The audio sensor must be dependable, sensitive and cover the full audio range of the human ear. The system is attempting to monitor the user’s respiration and discern it from the background noise. It is to also monitor the background noise and detect changes in volume and amount of audio. The audio sensor will use the specifications illustrated in Table 3.

Table 3 Audio Sensor Specifications

Audio System Requirements	The audio sensor shall detect minimal sounds of three decibels
	The audio sensor shall use less than one micro amp of current in a sleep state.
	The audio sensor shall use less than ten milliamps when in use
	The audio sensor shall have a failure rate of less than one tenth of one percent.

	The audio sensor shall have a frequency range from 0 hertz to 500 hertz
	The audio speaker will implement a range of audio frequency based on parameters set by the user.

2.4.3 Microcontroller Unit Requirements

The microprocessor unit (MCU) must have sufficient memory, sufficient number of GPIOs, low power consumption, small form factor, low cost, ideal programming environment, and good community support. Most MCUs on the market from the major manufacturers, for example STMicroelectronics and Texas Instruments, compete on each particular performance quality. Therefore, the performance requirements analysis is reasonable to assume an MCU can be found satisfying all the quality metrics desired. The price versus performance metrics for most MCUs on the market today more than fulfill the requirements of Knight Nite. The only consideration beyond performance is scalability. There are numerous efficiencies to be realized in more compact and simpler designs at volume production capacities. Knight Nite assumes 32-bit MCUs, versus 8-bit or 16-bit MCUs, are simpler to design and implement software.

Furthermore, all manufacturers provide MCUs with the common communications interfaces desired by Knight Nite, for example USB and potentially network interface circuitry. The estimate of required GPIOs does not exceed 16. Most GPIOs on an MCU have alternative functions for differing communication interfaces. However, commercial MCUs in the 32-bit category generally exceed 16 programmable input/output. The hardware requirements of the Knight Nite MCU are described in Table 4. Unless otherwise noted, each Knight Nite subsystem unit utilizes the same MCU.

Table 4 MCU Requirements

MCU System Requirements	The MCU shall have scalable or run/idle modes for power consumption
	The MCU shall have at least 16 GPIOs
	The MCU shall have USB support
	The MCU shall have at least 32KB of SRAM
	The MCU shall be 32-bit

	The MCU shall have a floating point unit
	The MCU shall be programmable in the C language

2.4.4 Light Unit Requirements

The lighting unit has two different functions that will be implemented. The first function of the light system is to detect ambient light from the environment and turn it into a format that can be interpreted by a microcontroller. Phototransistors will be required to convert the light photons into an analog voltage. From there, analog-to-digital converter will be required to convert the analog signal into a digital format that can be read by a microcontroller. The lighting system shall have its own microcontroller to take in the light data and provide a control signal for the second function of the lighting system.

The second function of the lighting system is to generate light to wake the user up. The lighting unit shall use LEDs to accomplish the task of providing light for the user. To protect the eyes of the user, the brightness of the unit shall not exceed 50 candelas and the LEDs shall not remain on for more than two minutes. In addition, the unit shall switch shall use batteries to power the LEDs. Batteries make the LEDs more portable and make it easier for the user to sleep with. The switching of the power to the LEDs shall occur after a control signal has been applied to a relay, and the LEDs shall not take more than five seconds to turn on after the control signal has been sent to the relay. A summary of the requirements can be found in Table 5.

Table 5 Lighting System Requirements

Lighting System Requirements	System shall provide light using LEDs
	System shall detect light using phototransistors
	LED brightness shall not exceed 50 candelas
	System shall take a control signal from microcontroller
	System shall switch power to LEDs using relay
	System shall not run for longer than 2 minutes

	System shall have its own microprocessor
	System shall switch power to LEDs in under 5 seconds of receiving control signal
	System shall use batteries to power LED

2.4.5 Cooling Unit Requirements

The cooling unit is an electromechanical system that alters the temperature of the forehead of the user. The main hardware components of this system include the pump, water reservoir, tubes, and contact patch. The pump will be used to cycle in the water from the water reservoir to the contact patch flowing through the water lines/tubes. Since the temperature of the water needs to be low enough to bring down the temperature of the user's skin, the reservoir will consist ice and water to simplify the process. An actual cooling system using convection will not be used since it is not within the scope of this project.

The reservoir of the liquid will be large enough where it will host enough water for the system to run properly. However it cannot be too large where it becomes impractical for the product's use. The size of the reservoir with liquid total will be 3-4 liters which is an ample enough of volume for the cooling system. Small rubber hoses will be used in order to provide a proper seal and not leak. For the contact patch, the patch must be made of a material that holds water well and will not leak. Furthermore, since cold liquid is flowing through this contact patch, the material needs to be able to not output condensation in order to keep the user dry. Therefore, the materials need to have a wicking characteristic in order to wick away all of the liquid that the cooling patch may produce.

The cooling system needs to be able to run in conjunction with the other major subsystems at the end of the implementation process. For example, the cooling system needs to be able to relay and receive information from the data processor based on the user's needs in order to correctly perform the operations set by the user. If the user needs the cooling system to turn off completely during their sleep cycle, the cooling system should be able to respond from the user interface controller. Furthermore, the cooling system must work along with the other major subsystems during the event of an emergency wake up. If the user needs to be woken up immediately, the cooling system must be able to rapidly cool the user's forehead in order to minimize brain damage in the event of a heart attack. Table 6 below shows the cooling system requirements that must be met during the final

design and implementation stages of Knight Nite. Following these guidelines are important in order to keep a standard in the design and functionality of the system.

Table 6 Cooling System Requirements

Cooling System Requirements	Run continuously for 8 hours (standard sleep cycle)
	Powered by DC power supply
	Cooling lines must be flexible
	Have its own microcontroller system
	Automatically controlled by a software
	Reservoir for the system not larger than 5 liters
	System sealed at liquid connections in order to avoid leaks
	Low operating noise in order to not disturb the user
	Runs in low power modes
	System to cost under \$75.00

2.5 Software Requirements

The software system for Knight Nite is divided between two platforms. The subsystem MCUs are responsible for collecting sensor data and doing automatic process control. The visualization and control unit (VCU) provides supervisory control and data presentation by way of a graphical user interface. In general, the software requirements are divided between the two platforms considering the separation of responsibilities.

Knight Nite utilizes a modified waterfall model of software development. Therefore, the requirements shall inform the analysis, design, implementation, and testing of the software. However, considering the short development cycle, software requirements may be revisited and revised during the implementation process. Changes in requirements during development shall be kept to a

minimum so as not to affect the testing procedures developed in later sections of this document. The software requirements for each MCU subsystem and the VCU are described and listed in the following subsections.

2.5.1 Visualization and Control Unit (VCU) Requirements

The visualization and control (VCU) unit software shall reside on a smartphone running a version of the Android operating system. Software residing on the component subsystem MCUs shall transmit normalized sensor data to the VCU. The VCU shall process the sensor data transforming values into user readable engineering units. The VCU shall provide a GUI based human machine interface (HMI) for displaying sensor data values, graphs, and device status. Furthermore, the VCU shall provide a GUI based control mechanism for supervisory control of each subsystem. The requirements for the visualization and control unit software are described in Table 7.

Table 7 User Interface Requirements

VCU Software Requirements	The software shall read sensor data transmitted over USB
	The software shall transform sensor data into human readable values in standard engineering units
	The software shall present data in the form graphs and readouts
	The software shall provide a plot of user sleep activity
	The software shall algorithmically determine user sleep activity based on motion and temperature
	The software shall provide a record of user sleep activity
	The software shall present subsystem device status
	The software shall provide subsystem device supervisory control functions
	The software shall provide on and off control

	The software shall present supervisory control and sensor data using a graphical user interface
	The software shall be stored and executed on a smartphone running the Android operating system

3. Division of Labor

In order to have a successful project, the labor will be divided into equal amounts of work for each team member. Considering the team's experience, the labor will be split based on each the area of study and amount of work each member can accomplish. For example, a member who has a background in embedded software development will have more responsibility than a member who has not developed any software.

In addition to a member's experience, certain modules of the project will need to be thoroughly tested in order to eliminate error propagating to other modules within the project. For example, a faulty, untested temperature sensor might give false readings on someone's body temperature and could mean catastrophic results in determining the user sleep cycle. In this circumstance, the particular hardware module would need to be thoroughly debugged, increasing the time and work needed to make it function properly

The division of labor was broken up into 4 major parts which are the light system, audio system, cooling and vitals, and computer systems as shown in Figure 1. By dividing the labor into these four parts, the result was that it was simpler to work together based on the needs of each section. For example, when a certain microcontroller is needed to be implemented, the computer systems engineer would lay out the requirements to the other 3 partners of the project to what they need to provide. Furthermore, it helps the other parts of the project because some may not be as knowledgeable in one field as others might be.

During the process of creating Knight Nite, Marcus Hobbs will be in charge of the MCU development and programming. Although each subsystem will have their own MCU and PCB design, Mr. Hobbs will make sure that all of the hardware and software will be simple and work effectively. For the audio system, Mark Hughes Atkins will be conducting multiple tests with various filters in order to fulfill the requirements for the audio portion of Knight Nite. Ahkeim Pierre will be in charge of the lighting system as well as researching different types of lighting units for the head unit to work well together. Furthermore, Mr. Pierre will implement ways to wake up the user peacefully while not disrupting any important stages of sleep. For the cooling and vitals system, Hieu Pham will be researching and implementing many mechanical parts for the cooling device as

well as create a monitoring system that measures the user's vitals. Furthermore, Mr. Pham will be doing research and comparisons of different power supply techniques in order to find the best way to provide different types of power to the system. A full in depth study in PWM fly back, buck, integrated switches, and other topologies will be explored in the power section of the system.

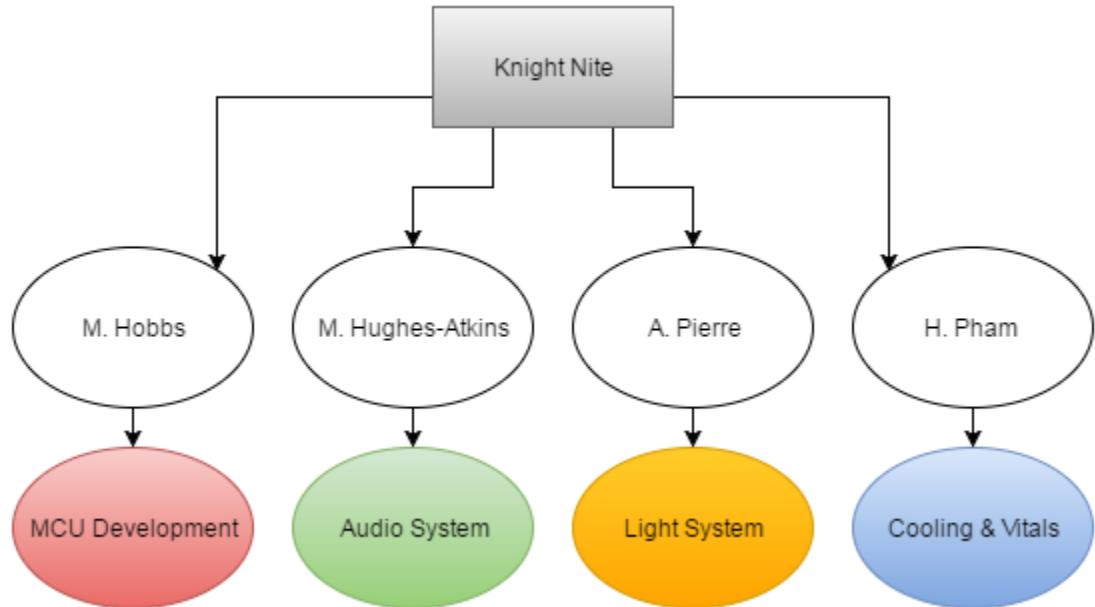

Figure 1 Division of Labor Flow Chart

The MCU development features 3 key sections as shown in Figure 2. The first section is power. Since the approach of Knight Nite is to have each subsystem with their own microcontroller based hardware and software, the power requirements have to be standard in order to satisfy the needs of each subsystem. By doing this, the power provided to each MCU will be the same. The method of deciding how much power to provide to the MCU's are based on which PCB needs the most.

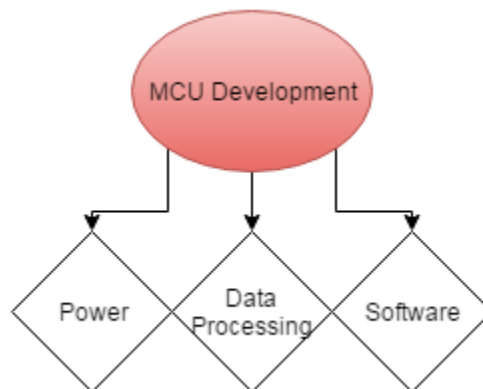

Figure 2 MCU Low Level Block Diagram

The data processing section is also based out of the MCU development. After all of the data from the individual MCU's from each subsystem are collected, the user must be able to interpret the data via a smart computer such as an android. By using this smart computer, the user will be able to look at smart information such as graphs, charts, sleep patterns, vital information, and other pertinent data that may be related to their sleep deficiencies.

Furthermore, the software is also based out of the MCU development which will be widely programmed in C. By making all of the individual MCU's be programmed in the same language, it standardizes and simplifies the design requirements. Furthermore, since each subsystem has its own MCU, troubleshooting the programming software will be simple since there are multiple scripts pertaining to each subsystem. For example, if there is a problem with the cooling system, it is fact that whatever programming issues arise has to come from its own individual MCU. By avoiding the monolithic approach, Knight Nite is simplified and efficient.

The audio system has 3 major sections that contribute to some of the key features of Knight Nite as shown in Figure 3. White noise will be provided by a speaker that is controlled with a man-made PCB and microcontroller. This speaker system will use white noise during various times of the night to see if the user responds positively or negatively to the treatment. Furthermore, the white noise speaker system will provide emergency wake up in the event the user is giving vital signs that are signaling a heart attack during sleep.

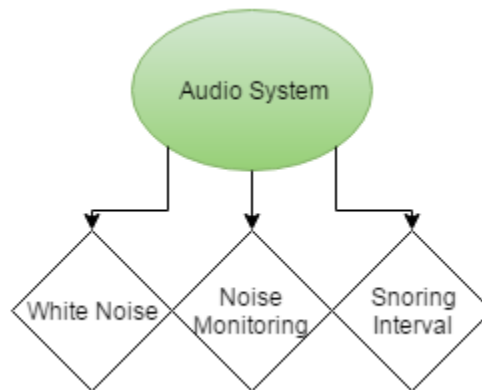

Figure 3 Audio System Low Level Block Diagram

Within the audio system is a noise monitoring system that will take data from the surroundings of the user while asleep. Many times, people who have trouble staying asleep are constantly woken up by noises that they cannot control and also do not realize that there is a noise disturbing their sleep. Therefore, the user will be able to look at sleep patterns versus the data provided by the microphone to see if there was any ambient noise that may have prohibited him or her from staying asleep.

Since the data the audio system will be taking in purely analog signals, there will need to be various analog to digital conversions in order to properly identify and review ambient noise. Many different filters will be tested to see what kinds of setups and schematics will be used in the final implementation of the audio system. Therefore, the audio system can bring in the noise it wants to hear rather than unwanted data that the human ear cannot be able to hear at all.

The light system has two main features that enhance the Knight Nite system as shown in Figure 4. The system will flash light-emitting diodes (LEDs) in order to wake up the user. Using an LED alarm allows the user to wake up more naturally as opposed to the abrupt sound of buzzer alarms. The lighting system will have a dedicated MCU that will have a built-in timer to wake the user up at the appropriate time.

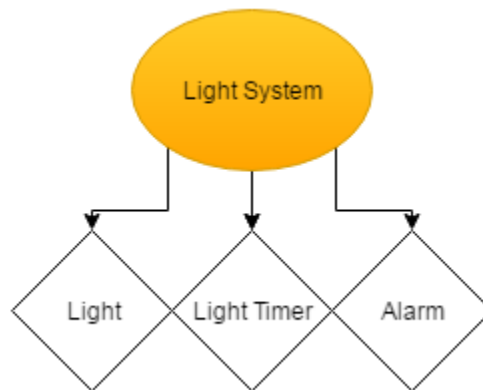

Figure 4 Light System Low Level Block Diagram

The lighting system will also detect ambient light in the environment. The light data collected will be used to monitor the environmental conditions of a user to determine how light affects the user's sleep.

The cooling system and vitals will be working together through a control system that will be created and programmed on its own microcontroller. The system has 3 major parts to it that are pertinent to the creation of Knight Nite as shown in Figure 5. The cooling motors, vital sensors, and feedback control system all have to work together in order to work properly. For example, the vital sensors have to give accurate readings to the cooling system in order for the cooling system to provide the correct amount of cooling to the user. This is all controlled through a simple control system.

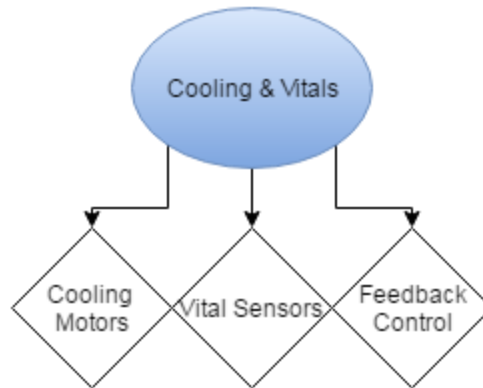

Figure 5 Cooling & Vitals Low Level Block Diagram

The cooling motors will be tested to make sure they can withstand the average sleep cycle. Furthermore, the hardware needs to be tested to figure out whether or not the pieces of the headpiece for Knight Nite will be able to build as well as simplified. The hoses or tubes for the cooling system need to be small and flexible to work with.

The vital sensors are a critical piece of Knight Nite. Since there are many other subsystems that rely on the vital readings for their system to work, they must be accurate and precise over a long period of time. Although there are a myriad of vital sensors on the market, the most cost efficient and simple sensors will be used in order to save time and money.

4. Research

Sleep is a recurring period of unconsciousness during which the brain and body engage in a series of restorative processes. The sleep state is characterized by periods of altered states of consciousness, reduced or completely inhibited voluntary muscle movement, and inhibited response to environmental stimulus. In mammals, sleep is categorized as either rapid eye movement (REM) or non-rapid eye movement (NREM) type sleep. A normal sleep pattern is a series of REM and NREM cycles occurring over a period of hours. NREM type sleep proceeds in several stages and is considered the deepest sleep state characterized by suppressed brain activity and paralysis. REM sleep is associated with dreaming and is the lightest sleep state characterized by rapid eye movement and nearly wakeful level of brain activity.

4.1 Sleep Stages

Sleep proceeds in a succession of these stages typically four of five cycles per night each cycle lasting approximately 90 minutes. NREM is logically separated into three stages N1, N2, and N3. N3 is considered deep sleep [4]. The American Academy of Sleep Medicine (AASM) defines the set of sleep stages [5]. Deep sleep is also known as slow-wave sleep characterized by an EEG reading with a one Hertz frequency. Slow-wave sleep is responsible for several restorative

functions in the human brain. Slow-wave sleep corresponds to consolidation of new long term memories. Those that suffer from a primary insomnia sleep disorder have trouble forming memories following a period of disturbed rest. Furthermore, during slow-wave sleep, the largest amount of growth hormone is secreted from the pituitary gland [6]. Sleep studies suggest that after a period of sleep deprivation there is rebound effect on slow-wave sleep. The next slow-wave sleep cycle will last for a longer period of time. Studies indicate when brain temperatures reach certain levels slow-wave sleep activates. The lack of slow-wave sleep may also be an indicator of high blood pressure. The lack of slow-wave sleep is a major health risk and possible indicator of future cardiovascular events [7].

REM sleep occurs as the sleeper exits slow-wave sleep and generally occurs every 90 minutes [9]. Sleep in the REM stage is referred to as paradoxical sleep because the sleeper is harder to wake even though his brain activity is highest. The purpose of REM sleep is not completely understood. However, REM deprivation leads to cognitive impairment and potentially psychosis and hallucination. A lack of REM sleep causes a rebound effect on the next sleep session [10]. This rebound effect suggests REM sleep is necessary at a biological level. However, the exact benefits of REM sleep have not been identified. REM sleep deprivation is positively correlated with alleviation of depressive symptoms [11]. Many antidepressants target this effect by decreasing time spent in the REM stage of sleep. Brain energy use can exceed the energy used during waking.

Sleepers typically awake just after or in the middle of REM sleep. The sleep-wake cycle is affected by the individual's circadian rhythm. A circadian rhythm is any biological process governed by a periodic oscillation of 24 hours. Furthermore, circadian rhythms in mammals are governed by the presence and absence of light and body temperature. The specific parameters that can affect a circadian rhythm by adjusting either forward in time or backward are called zeitgebers. The specific process of adjusting a circadian rhythm by changing external cues is called entrainment. In mammals, photoreceptors in the retina signal the presence or absence of light to the pineal gland. The pineal gland secretes a hormone called melatonin that modulates or regulates the circadian rhythm. For example, melatonin production peaks at night due to the absence of light and can cause the beginning of a sleep session. The timing of exposure to light can advance or delay the circadian rhythm. Disruption in the sleep-wake circadian rhythm is correlated to negative health effects. In particular, disruption is believed to be the cause of some severe cardiovascular disorders.

4.2 Sleep Disorders

Sleep is a fundamental activity in humans accounting for approximately one-third of a human lifetime [2]. The purpose and mechanism of sleep are an on-going source of scientific investigation. However, there is no consensus in the scientific

community of the exact purpose of sleep. What is known is sleep deprivation has myriad adverse side effects on human physiology and in particular cognitive function. Research suggests sleep deprived humans suffer memory loss, reduced cognitive performance, reduced or impaired reaction time, and cardiovascular disease. Sleep deprivation can induce severe mental illness including psychosis and bipolar disorder.

This project is not intended to diagnose or treat any type of medical condition. Some disorders, such as sleepwalking, will be obvious to any sleep monitoring system. Nonetheless, this system cannot decide on such matters for liability reasons and also because it will not be designed to do so. A system capable of aiding in diagnosis is called a clinical decision support system (CDSS). It is worth consideration that some sleep disorders will prevent the sleep monitoring system from functioning properly, perhaps in a nonobvious way. In such cases, and in obvious cases like sleepwalking, the system may provide clues that professional consultation is recommended.

The circadian rhythm is directly affected by the use of prescription medications such as benzodiazepines and the abuse of drugs and alcohol. Studies indicate a correlation between drug and alcohol addiction and disruption of circadian rhythm. The exact nature of the correlation is not clear. Adjusting the circadian rhythm and improving sleep length and quality may help prevent relapse in drug and alcohol addicts. The Knight Nite system is not intended to improve sleep in the presence of drug and alcohol abuse.

The use of a microphone or respiration monitoring may help identify snoring, which is a possible sign of sleep apnea. However, there are many causes of snoring, including obesity, alcohol intake prior to sleep, or simply jaw position [3]. Users may have interest in monitoring their snoring activity for many reasons, from health concerns, amusement, or just because during sleep there is no awareness of whether one snores. Snoring may result in periodic waking throughout the night without a person realizing it, and may result in poor quality sleep. It is therefore a monitoring goal of interest, but not a requirement for this project.

4.4 Existing Projects/Products

4.4.1 Knight Time

One existing project called *Knight Time* was designed and created at the University of Central Florida. It is a sleep management system that allows the user to monitor sleep patterns. It also provides a user interface providing different ways to help the user wake up. However, it does not provide any viable solutions to help the user sleep. It only monitors behavior and sleep cycles while picking a certain time to wake up the user.

Knight Nite will focus on the actual treatment to the user using a feedback system in order to put the user to sleep faster. For example, one of the main treatment options for our project will integrate a cooling system that cools the user's forehead. Similarly, there is going to be a headpiece worn on the user to do this. Therefore, there are many components of *Knight Time* that we can relate to such as the sensors system however we will be going more in depth in the treatment aspect of our senior design project.

One key difference from *Knight Time* that this project will feature is a modular approach to the design phase. Knight Nite uses a monolithic approach which sends all of the signals to the different subsystems back to a single main MCU. Although this approach is cost efficient and most ideal for the majority of engineering applications, the monolithic system was picked because it offers the simplest design and is easier to troubleshoot during the testing phase.

4.4.2 Knight's Wireless Baby Monitor

A previous senior design project called, "Wireless Baby Monitor" was created at the University of Central Florida. It is a monitoring unit with a temperature sensor, motion sensor, and audio sensor placed at the head of the crib. All sensors are trained upon the infant comparing the outputs against known parameters to hopefully prevent the infant from succumbing to SIDS or SUIDS. Similarly, our project will use similar sensors in order to monitor the user behavior, but in addition our project will interpret the information provide from the sensors to provide treatment to the user.

4.4.3 Withings Aura Sleep System

The Withings Aura Sleep System is a sleep monitoring and improvement device produced by French wellness company Withings. The Aura system combines sensors that monitor motion, light level, and sound level to provide management and feedback to the user. The Aura system is composed of a bedside speaker and light emitting alarm and a sensor "mat" placed underneath the mattress. The alarm unit emits red and blue light and music designed to put the user to sleep or wake her up.

The unit is controlled via an application hosted on either android or iOS capable smartphone. Additionally, there are rudimentary controls on the bedside alarm unit. The unit is capable of interpreting user motion sensed by the mattress sensor and providing sleep cycle information on the Aura application. The feedback from the user's sleep cycle is used to inform the sleep and wake programs on the bedside unit.

4.4.4 SleepRate

SleepRate is a product that was created to assist with improving sleep. The device includes a heart rate monitor and it tracks any sounds in the environment. There is also an alarm that triggers at an optimal time when the user is supposed to wake up as well as a personalized assessment. Similarly, our project will use sensors to monitor vitals for analysis and feedback into a control system. The user will also be asked to take an assessment in order for the product to provide the best solution to improve their sleep.

5. Subsystem Components

In today's day and age, there are a myriad of existing systems that are able to monitor vital signs of a human being and record biometrics. Taking multiple existing products into consideration will help in the design process of this subsystem in Knight Nite. The majority of heart monitor sensors outputs a digital signal through a built in analog to digital converter.

By simplifying the requirement for the output to be digital, it is more efficient to take that data and display it as high versus low chart. For example, a high signal would signify that the user's heart is beating. A lower signal means that it is in the down motion of the actual heartbeat. Using a simple sensor to measure the heart rate will be effective in implementing it into a microcontroller to interpret the data into content that will help the user realize what is going on throughout the night. An important feature of Knight Nite is to monitor the heart rate of the user. Some of the best current products that monitor heart rate include TomTom Spark, Garmin Forerunner 225, and FitBit.

Although some of these have very complex features, the main objective in the design's heart rate monitoring feature will be simple and efficient. During the research of heart rate monitors, it was decided the simplest and most effective output format would be a digital output. That way it would be easy to implement into the MCU and show the data effectively in the user interface.

Another important feature to monitor in this system is temperature. Including the implementations in the user interface, temperature will be needed to control the cooling system. The cooling system turns on and off depending on what the skin temperature of the user's forehead is at the current time. When it falls above a certain threshold, the system turns on. If the temperature falls below a certain threshold, the cooling system will turn on. Therefore, temperature must be accurate and precise in order for the cooling system to work properly.

Furthermore, the temperature of the user will be used in order to provide data in the user interface. After waking up, the user will be able to analyze their own sleep pattern and see at what times of the night their temperature fluctuated.

Based on this data, they can determine which times of the night their sleep was disturbed and if the temperature of their skin had anything to do with their sleep patterns.

5.1 Heart Rate

The pulse sensor amped heart rate monitor was chosen to be used because it outputs a simple signal that is easy to interpret for the STM cortex MCU design. It features a ground, power, and output signal wire that can be easily programmed with the project made MCU/PCB. Furthermore, this product is much cheaper than some of the other products on the market coming in at the 10 dollar range. Furthermore, this product is small which can be compared to the size of roughly a quarter. This makes this heart rate monitor ideal for the implementation of the vitals unit because of the flexibility of positioning the heart rate sensor on any location on the user.

Since the pulse sensor amped heart rate monitor is designed to be placed on the user's finger, there may be further modifications to the head unit device. After purchasing the product, there will be further testing on how the sensor works and whether or not it is as efficient and accurate as advertised. Furthermore, there will be testing of the sensor to see if it can be placed any place other than the user's fingers. For example, since Knight Nite's head device will be placed on the user's head, there may be an implementation for the sensor to be placed near the forehead or neck region. Therefore, the system as a whole will be a lot less cluttered and the sensors can be in close proximity with each other without having to have loose wires run all over the user's body. Simplification of this unit as well as other units (cooling/audio/lighting) will be explained further in the testing sections.

5.2 Temperature

Knight Nite will have temperature measurements from two different sources. The first source is the ambient temperature in the room. The second temperature sensor will be measuring the skin temperature of the user's forehead in order to provide data for the cooling system. The ambient temperature in the room will be utilized in the user interface and will be helpful for analysis of the user's sleep patterns throughout the night. Since the user will be able to view the change in temperature throughout the night they may be able to link certain sleep problems with the sudden change in temperature of either their skin or the ambient temperature of the room they are sleeping in.

For the ambient temperature of the room, the sensor will be placed away from the user in order to get accurate readings from the sensor. If the unit was too close to the user, the user could affect the temperature of the ambient temperature sensor since the heat of the user would affect the reading. Therefore, the sensor will be placed away from the user so an accurate

measurement of the ambient temperature will be taken. For the skin temperature for the forehead, the sensor will be placed on the user's forehead which will be attached to a head mounting device that the user wears.

The head unit is designed to be comfortable so that the user does not notice that he or she is wearing it during their sleep. Therefore, the sensor will need to be integrated into the head mounting device effectively in order to accomplish 2 goals. The first goal for the temperature sensor is to be comfortable enough so that the user does not recognize or is bothered by the temperature sensor itself. The second goal is to take accurate readings of the forehead in order for the data to be used in other subsystems.

Since the ambient temperature system will be separated away from the user, there are very few physical constraints in terms of the size of the device. Therefore, the ambient temperature system can be as large as necessary. Unlike the ambient temperature system, the skin temperature system will have constraints in terms of the size of the package. Further research had to be done in order to determine the most appropriate temperature sensor to be utilized in the project.

There are many different ways to measure the temperature of the skin. For this application, a sensor needs to be implemented to monitor the skin temperature over a period of time without wasting much power. Common methods used to measure the temperature the human body are by the forehead (NFC or LCD sticker), wrist, ear, and temporal artery. For this project, a reading from the forehead is necessary in order to regulate when the cooling system for the forehead is activated.

An integrated circuit temperature sensor using a transistor is a great way to measure core temperature however it is not the most practical to measure the temperature on the surface of the skin. Based on research by Texas Instruments, an IC temperature sensor offers the best temperature linearity readings as well as the simplest circuit layout. This is only for temperature readings of core body temperature. Therefore, an infrared temperature will be utilized with a "can through-hole" package. This type of sensor allows for simplicity and efficiency in measuring the immediate surface temperature of the skin. Table 8 shows the 3 different temperature sensors that were considered for this subsystem.

The TMP006 is an infrared temperature sensor that features a contactless thermopile in order to take temperature readings. They are fully integrated MEMS that have the ability to measure the temperature of any object without directly touching it. The sensors absorb infrared signals at wavelengths from 4um to 16um. The sensor also has a math engine built into it that is able to perform all of the equations on the chip itself. Furthermore, the TMP006 features a shutdown feature and also provides a digital output.

Table 8 Temperature Sensors Comparison

Device	TMP006	MLX90614	ZTP-115
Manufacturer	Texas Instruments	Melexis	General Electric
Accuracy	± 1 °C	± 0.4 °C	± 1 °C
Output Type	Digital	Digital 10 bit	Voltage High/Low
Current	240 uA	2mA max	N/A
Voltage Range	2.2-3.6V	3-5V	N/A
Operating Temperature	-40 to 120 °C	-40 to 120 °C	-20 to 100 °C
Package	DSBGA	TO - 39 Can	TO-5 Can
Size (mm)	1.6 x 1.6 x 0.625	9.1 x 9.1 x 2.1 mm	9.25 x 9.25 x 3.6 mm
Price	14.95	19.95	4.40

The data that comes out of the TMP006 is an I2C and SMBus compatible. The operating temperature for the TMP006 is between 0 and 125 degrees Celsius which is great however the sensor can only take measurements between 0 and 60 degrees Celsius. Therefore, this is not the best sensor for Knight Nite's integration with measuring the surface temperature of the user on the forehead. However, this could be integrated with the ambient temperature system because there are fewer constraints with the ambient temperature sensor.

The General Electric ZTP 115 is another non-contact thermopile that was considered for the implementation of the skin temperature system for Knight Nite. It features a single infrared module which provides a voltage output for the microcontroller it's using. The sensor has high sensitivity and a fast response time. The ZTP 115 is also cheap which makes it desirable for this type of project. Although the ZTP 115 is affordable, it does feature an analog output which is undesirable for this design. A digital output sensor is a lot more favorable due to the ease of use and the need of an analog to digital converter.

Figure 6 provided by General Electric shows how the output voltage varies with the temperature of the object. As the temperature of the object increases, the output voltage increases. Therefore, the output signal from the sensor is not entirely consistent due to the fact that the temperature of the object may vary. This could lead to further complications in the design process when trying to program and implement the ZTP 115.

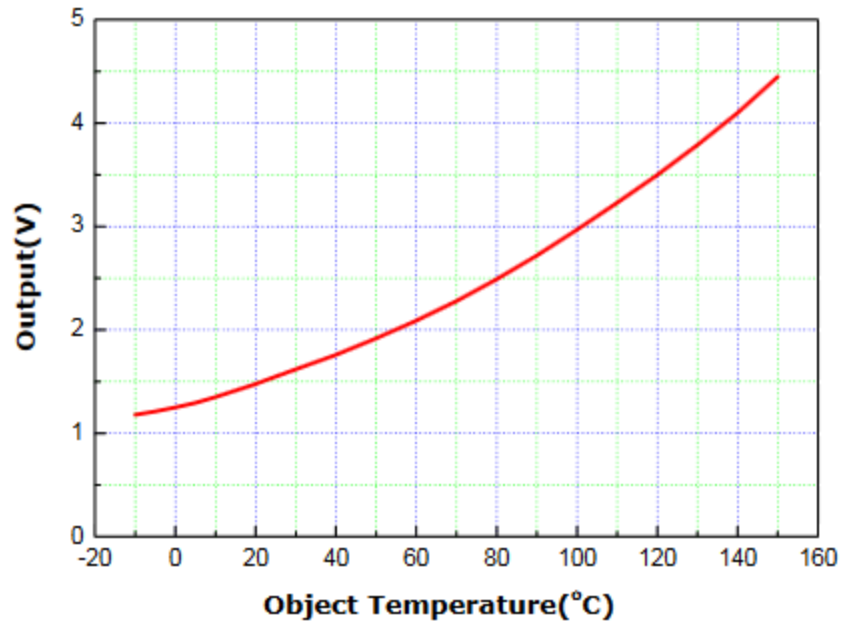
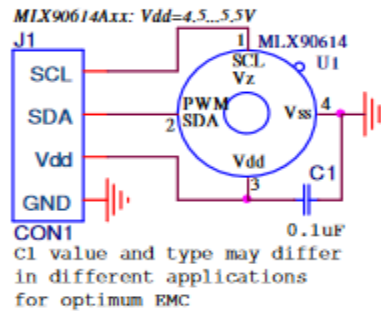

Figure 6 ZTP 115 Output Voltage vs. Temperature

The MLX90614 features a contactless infrared thermometer that features a metal through hole can design. It offers a digital output which is favorable for the implementation of the temperature system. Furthermore, it is highly sensitive and has a wide operating temperature. Due to its low cost and easy integration, it is highly popular among other project as well that need to measure the temperature of an object through a contactless method. Furthermore, the sensor has different packaging options which allow for versatility in the design portion of Knight Nite. The package under consideration is the MLX90614 that is integrated on a flat printed circuit board.

Figure 7 features a diagram by Melexis showing the MLX90614 functional diagram utilizing a connection to SMBus. The four connections feature power, ground, and 2 signal outputs SCL and SDA which can be easily implemented into any simple microcontroller such as an MSP430 or STM Cortex processor.

Functional diagram



MLX90614 connection to SMBus

Figure 7 MLX90614 by Melexis

Throughout researching the different models of temperature sensors for Knight Nite, there are 3 that stood out for the implementation of the vital system. The Melexis MLX90614 infrared temperature sensor makes the most sense in using it to implement with a simple PCB because it outputs a 10 bit digital signal and has the most precise and accurate temperature readings.

Since the cooling system will run based on the readings given by the temperature sensor, it is important that the temperature sensor can give readings as small as possible in order for the cooling system to be programmed at more precise temperature readings. For example, the programming for the cooling system is more suitable to be programmed at 70.05 degrees rather than just 70 degree Fahrenheit. The MLX90614 allows for more precision in readings while being cost efficient and small in size to eliminate bulkiness and space requirement.

Figure 8 features to MLX90614 sensors in two packaging options. The first option features the temperature sensor with pins that is ready to be soldered onto a printed circuit board. The second package option features the MLX90614 already integrated on its own printed circuit board. Since the second option is more compact design, it will be the one that will be implemented in the temperature system.

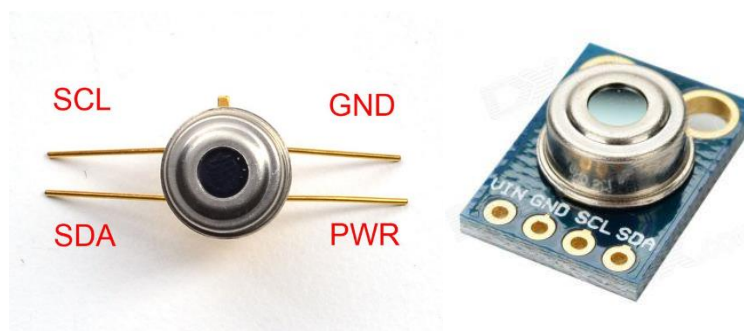

Figure 8 MLX90614 sensors

5.3 Motion

There are many different ways to monitor the movement of someone sleeping. The most popular device used to do this is an accelerometer. There are devices and units on the market today that uses accelerometers with most smartphones such as androids and iPhones. Furthermore, there are many exercise devices such as the Fitbit that use accelerometers to measure activity.

A big problem with measuring the movement during the sleep cycle with accelerometers is the ability to catch motion at the slightest movement of the user. Therefore, the requirements for the motion sensor are a high enough sensitivity level where it can monitor the movement of the user at very precise and accurate rates. Furthermore, the sensor will be required to remain on for an extended period of time during sleep.

The three most researched motion sensors implemented for Knight Nite came from two companies, Analog Devices and Invensense. Both companies offered great products that were proven in many other design projects. For the purpose of this design, the requirements included was that it had to be simple and efficient. Therefore, there were many other smaller motion sensors such as the PIR motion sensor that was considered. Table 9 shows the comparison of various motion sensors that were researched to compare in order to pick out the most appropriate sensor for this subsystem.

Table 9 Motion Sensor Comparison

Name	ADXL335	ADXL345	MPU6050
Manufacturer	Analog Devices	Analog Devices	Invensense
Sensitivity	300 mV/g	256 LSB/g	16384 LSB/g
Axes	3	3	3
Output	Voltage	16 bit Digital	16 bit Digital
Voltage	1.8-3.6V	2 to 3.6V	2.375 to 3.46V
Current	350uA	145uA	4mA
Operating Temperature	-40 to +85DegC	-40 to +85DegC	-40 to +85DegC
Package type	LFCSP	LGA	QFN
Dimensions	4 mm x 4 mm x 1.45 mm	3mmx5mmx1mm	4mmx4mmx0.9mm
Estimated Price	14.95	17.5	7.99

The PIR motion sensor was considered because it offered simplicity in design and was extremely cost efficient. It featured only 3 wires coming out of the sensor for power, ground, and the motion signal. Although this device was a favorite for the group, the simplicity of it was also one of its weaknesses. The reason behind its weakness of it being too simple is that there are no possibilities

for expansion. The signal that it outputs is just a high and low signal. There are no 3-dimensional monitoring features that some of the more advancement accelerometers may have. Furthermore, the design of Knight Nite requires for monitoring the movement of the user over a long period of time (8 hour sleep cycle). Therefore, the features of this sensor do not provide ample enough data for a long period of time.

The MPU6050 is the most desirable sensor for the design of Knight Nite because of its ability to track x and y coordinate body movements. Furthermore, the sensitivity of the MPU6050 is really high which will serve as a great sensor for the purpose of this project. Since the user will be mostly static during sleep, any movement created by the user will need to be recorded at any time. As seen in Figure 9, the MPU6050 is small in size which makes it desirable for the motion detector subsystem.

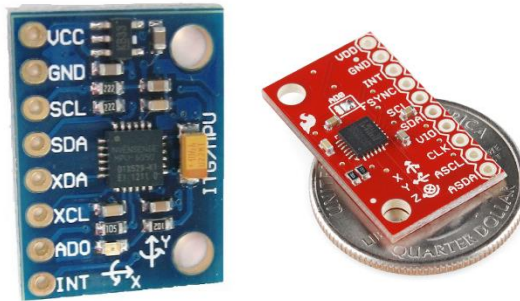

Figure 9 MPU6050 Sensor

The MPU6050 also matches the power requirements of Knight Nite. There is a low current draw out of the MPU6050 of about 4mA which when powered by a small battery or power source will be plenty to go through multiple 8 hour sleep cycles. Furthermore, the output type of the sensor is a 16 bit digital which will be easy to implement on the STM cortex based PCB that will be created via cad software.

The size consideration of this sensor was also taken into account. The sensor could not be too big as it would make the head device of Knight Nite too bulky. The surface mounted sensor is smaller than the size of a quarter which makes it perfect to implement within Knight Nite.

5.4 Audio

The microphone will capture the audio signal from the user's breathing and filter out sound levels of the general environment. Since the purpose of the microphone is to record the user's breathing, a low pass filter will be designed to suppress background noise and allow the user's breathing sound to pass

through. In order to do so, sensitivity and low signal noise are the important requirements in selecting a microphone for this project.

There are various microphone technologies, such as piezoelectric, condenser, fiber optic, carbon and even liquid. An electret microphone is a type of condenser microphone that eliminates the need for a high-voltage bias supply by using a permanently charged material. Considering our budget for this project, an electret MIC is the best money value due to their performance and low cost. However, electret microphones were once considered low quality, but now the best ones can rival traditional condenser microphones in every respect and even offer long-term stability and ultra-flat response needed for a measurement microphone [12]. Omnidirectional microphones are the most desirable for ambient sounds especially when considering placement.

The frequency range of the microphone must be sufficient enough to detect the user's breathing sounds, since majority of adult breathing occurs under 500 Hz. Considering the economic constraint of the project low cost is the primary consideration while durability, directivity, and frequency response were the secondary considerations in selecting the microphone. The low-pass filter will be design to limit the frequencies to a range of 0 Hz-300 Hz. Since the highest peaks of intensity regarding human breathing occur in that frequency range [18]. The third order low-pass filter that was designed allows the magnitude to reach zero exactly one decade after the cutoff frequency. The phase response is shown in Figure 2.5.

After researching several types of microphones the team decided to select the AOM4544P2R since it is the most compatible for our project. There are several microphones in the market that can be used for this project shown Table 10. One of the attractive feature is that it has a larger frequency response and very low voltage requirements. The AOM-4544P-2-R is an overall better microphone; it has higher sensitivity, lower supply voltage requirements, a wide frequency response, and lower price. The tradeoff is a slightly larger size, although the AOM has 5 mm leads versus 2.8 mm leads on the TOM, which will make testing easier. The AOM-4544P-2-R is the one that closely resembles the specifications for the project and it can be used to detect the breathing.

The AOM-4544P-2-R features include a frequency range from 20 Hz - 20 KHz, omnidirectional, super clarity, distortion-free response, and Pin type mounting. So it is possible to place the sensor in a head mounted device if needed, but omni directional feature will allow us to place it anywhere that is the best solution for also capturing ambient sounds.

Table 10 Microphone Comparison

Device	TOM-1545S-C33-R	POW-1644L-LWC50-B-R	AOM-4542P-R
Directivity	Omni-Directional	Omni-Directional	Omni-Directional
Impedance	2.2 kOhm	2.2 kOhm	2.2 kOhm
Current Consumption	.5 mA	.5 mA	.5 mA
Package Size	4 x 1.5 mm	6 x 1.6 mm	9.7 x 4.5 mm
Standard Operating Voltage	2 Vdc	2 Vdc	1.5 Vdc
Max Voltage	10 Vdc	10 Vdc	10 Vdc
Sensitivity	-45 ± 3 dB	-44 ± 3 dB	-42 ± 3 dB
SIGNAL TO NOISE RATIO (MIN.)	60 dB	60 dB	60 dB
Terminal	Solder Pads	Lead Wire	PIN

5.5 Lighting

The two main objectives of the lighting system will be to detect light and generate light. The detector will detect the ambient light in the environment to see if user sleep is correlated to changes in ambient light. The light generator will act as an alarm to wake up the user at a specified time. There are three types of components that can be used for light detecting purpose: a photo resistor, photodiode, or phototransistor.

5.5.1 Light Detection

One device that can be used as a photodetector is a photo resistor. A photo resistor, also known as a light-dependent resistor, is a resistor that changes resistance when exposed to light. The photo resistor is comprised of a semiconductor that has high resistance. When photons hit the material, electrons are excited and electricity is produced, which decreases the resistance of that semiconductor material.

Another photosensitive device is the phototransistor. Phototransistors are bipolar semiconductor devices that have a base that is exposed to light. They work similar to photodiodes, except phototransistors provide current amplification and voltage. The current and voltage produced is proportional to the amount of light striking the base of the phototransistor. Phototransistors have the advantage of being small in size and usually cost less than a dollar, making them a fairly cost-effective choice.

5.5.2 Photodetector Voltage

In order to convert the light voltage into a format that is readable by the main MCU, we can use an analog-to-digital converter. The reason why using an analog-to-digital converter is a good option is because the voltage output from the photodetectors will be in an analog format which is extremely complicated for MCUs to understand. MCUs operate entirely on ones and zeroes and an analog-to-digital converter allows us to sample the analog signals and translate them into ones and zeroes for the MCU to understand.

Another way that we can get data to a format that the MCU can interpret is to use a logic level converter. A logic level converter steps up and step downs voltage. Some MCUs use TTL logic to split voltage ranges into the category of either a one or a zero. TTL logic normally states that voltages below five volts are considered to be logic zero; voltages greater than or equal to five are considered to be logic one. A logic level converter can translate either up or down depending on where the voltage aligns with TTL logic. The second advantage is that if the voltage that is output from the photodetectors can be stepped down into voltages that are more manageable by the MCU.

One disadvantage to using logic level converters is that even if logic level converters are used, the MCUs still only understand logic ones and zeroes in order to do anything with the voltage from the photodetectors. A digital-to-analog converter will need to be used, either inside or outside the MCU, to allow us to make sense of the data and make observations.

5.5.3 Light Generation

In order to generate light for the user to wake up, light-emitting diodes (LEDs) can be used. LEDs are semiconductor devices that produce light when current is passed through the device. The types of LEDs are single color and multi-colored LEDs. A red-green-blue (RGB) LED uses a combination of three LEDs, and it can be used to produce all colors of the spectrum. This project will use LEDs to wake the user up because light is the natural stimulus that triggers the process of waking up, like sunlight. When choosing an LED, factors such as turn-on voltage, intensity, and power consumption are important.

5.5.4 LEDs

Primarily, LEDs are used as lighting sources because they are the easiest to mount on a circuit board; light bulbs are too big and difficult to implement on a circuit board. We want to use LEDs in order to wake the user up in order to make it much smoother for the user to wake up in the morning. Oftentimes, buzzer alarm clocks abruptly wake the user up and throw the user's sleep cycle off rhythm. Another issue with buzzer alarms is that sometimes users tend to press the snooze button on their alarm clocks in order to get additional sleep. This is a result of their sleep cycle being interrupted by the buzzer. Hitting the snooze button repeatedly can also cause an unwanted sleep cycle due to the short bursts of waking up and going back to sleep over the period of several mornings. With our LED alarm clock feature, users will be able to transition into an awakened state much easier when they need to wake up.

The human body works on a sleep-wake schedule called circadian rhythm. The circadian rhythm tells the body when it should be awake and when it should be asleep. Light and darkness are the two main indicators that trigger the internal clock. When it is dark, the user should be sleeping and when it is light out, the user should be awake.

A hormone called cortisol plays an important role in providing us with energy to wake up. In the morning, cortisol levels are high because the body is exposed to light. Yet, in the evening cortisol levels are low due to absence of the sun. Another hormone called melatonin works in the opposite manner of cortisol. Melatonin is produced in low quantity in the morning and higher quantity at night. In other words, melatonin is the hormone that helps us fall asleep.

Since the sunlight in the morning helps the body wake up naturally, it made perfect sense to incorporate an alarm using LEDs into the design of our project. Using LEDs was based under the assumption that the user will be wearing some type of sleep mask throughout the night in order to block out as much light as possible to get a good night's rest. This is especially the case for people with sleeping disorders or people who find it difficult to sleep in the presence of even the smallest amount light.

5.5.5 LED Strips

LED strips can also be used to provide lighting to wake the user up. LED strips are made up of surface mounted LEDs placed on flexible circuit boards. With the use of LED strips, strips can be cut to the right length to get a more accurate fit on the mask. Moreover, LED strips will reduce the amount of time it takes to manufacture. The Knight Nite lighting system will use somewhere between 20 to 30 LEDs. If individual LEDs are purchased, it will take more time to solder all the

parts together. The LED strips allow for simpler interconnects in order to incorporate a higher amount of LEDs into the lighting system.

Another nice thing about LED strips is that LED strips have a structure, so it eliminates the need to find a flexible sheet to incorporate LEDs into. From a cost perspective, LED strips gives the most bang for your buck. A spool of 3000 LEDs can range from \$7 to \$16, which is over 180 LEDs for each dollar spent, making LED strips a very cost effective option. One disadvantage is that if a failure occurs on one of the strips, an entire strip could go out. As a result, the amount of LED lighting generated will be reduced. This is a minor issue that can be resolved by adding more LED strips.

5.5.6 Surface Mount vs Through-Hole

Surface mount LEDs are great because they are smaller in size than through-hole LEDs. This allows for the incorporation of many LEDs into the design without adding too much bulkiness. The problem with using surface mount LEDs is that it will take long time to solder all the LEDs. Increased effort for mounting LEDs could slow down production time. Conversely, through-hole LEDs are larger in size than surface mount LEDs, so fewer LEDs can be used for the lighting system. Through-hole LEDs protrude out more than surface mount LEDs and will require a housing that has a rigid structure to prevent the LEDs from resting directly on the user's eyes.

5.5.7 LED Orientation

There are different ways to wire the LEDs. First, the LEDs can be connected in series. One good thing about wiring the LEDs in series is that the current draw from the power source is the same for all LED. Having a constant current draw allows for a longer battery life which means that users have more time to use the product between each charge.

However, there are some drawbacks to connecting the LEDs in series. For one thing, a larger voltage source would be required in order to power all of the LEDs. Each LED has a forward voltage of 3.2 volts, so ideally 32 volts direct current (VDC) would be needed to power 10 LEDs. There are ways to use smaller voltage sources to power multiple LEDs in series. One way is to use LED strips; if LED strips are used, then as low as 12 volts can be used to power hundreds of LEDs.

Another disadvantage of connecting the LEDs in series is that as the number of LEDs is increased, the more voltage would be required to power the LEDs. Wiring LEDs in series also makes it difficult to troubleshoot if an LED fails. One would have to do a continuity test on all of the LEDs in order to find out which

one is faulty. If the LEDs are soldered on a circuit board, you would have to remove the faulty LED and replace the individual LED, or replace the circuit board entirely. Replacing the circuit board could involve purchasing new components, purchasing new circuit boards, or paying for soldering services. Connecting the LEDs in series would increase the cost of maintenance, increase the amount of repair requests from the user, and potentially decrease the amount of future sales due to unsatisfied customers.

The second method of wiring the LEDs for the lighting system is to connect them in parallel. Parallel connections allow for the power source to supply the same voltage to all LEDs. Standard LEDs can require up to three volts turning on so low voltage supplies can be used to power multiple LEDs. A major drawback to connecting LEDs in parallel is that there is more current drawn from the power supply. Higher current draw will increase the rate at which the power supply discharges. This is not favorable since users will have to charge the product more often for operation.

5.5.8 LED Brightness

Brightness is a very important factor to consider when picking LEDs. We do not want for the LEDs to blind the user or cause significant damage to the eyes of users. At the same time, we want the LEDs to be bright enough to wake the user up. Typically, the brightness of LEDs is measured in candelas (cd) or millicandelas(mcd).

According to an article titled *Light and Human Health: LED Risks Highlighted*, a brightness of 10,000 candelas per square meter is enough to cause some discomfort for the user. So, we want to stay as far away from 10,000 candelas as possible. Lighting inside houses range from about 200 to 300 candelas. Similarly, the intensity of a typical LCD screen ranges from 250 to 350 candelas per square meter. The LCD brightness is sufficient for a user sitting one to two feet from the screen, but the LEDs for this project will be inches away from the eyes. At that close of a distance, the user could experience some discomfort. This project will use LEDs where the brightness scaled down to around 20% of the typical LCD to provide the adequate brightness for the user.

5.5.9 Control Signal

The light generating system needs a control signal in order to turn at the appropriate times. If there was no control signal the LED lights would be lit throughout the night, or the LED lights would require the user to manually turn the LEDs on. The user would be asleep so it would not be possible for the user to turn on the LEDs manually. The control signal can come from an MCU dedicated

to the lighting system. The lighting MCU could take a command from the main MCU to trigger the process of turning on the LEDs.

5.5.10 Amplification

In the event that the control signal is not enough to trip the relays to switch power to the LEDs, some form of current or voltage amplification will be needed. The control signal from the MCU can be amplified in two ways. The first way is to use a transistor. There are two types of transistors considered for this project, bipolar junction transistors (BJTs) and metal-oxide semiconductor field effect transistors (MOSFETs). A bipolar transistor allows for the amplification of current without having to change the voltage applied to the base of the transistor.

On the other hand, MOSFETs require an increase in voltage to the gate of transistor in order to increase the current used to drive the LEDs. If a MOSFET is used, then depending on the gate-source voltage threshold, an operational amplifier will be required to increase the voltage applied to the gate of the MOSFET to allow more current to drive more LEDs.

Another way to get amplification is to use an operational amplifier (Op-Amp). Operational amplifiers use feedback and high input impedance to amplify the applied voltage, which in this case is the control signal sent from the MCU. The issues with operational amplifiers is that you will have to make sure that the output is stable, otherwise the desired output cannot be achieved.

5.5.11 Switching Power to LED

A switch will be needed to enable the power source to provide power to the LEDs when the control signal has been applied to the light generating system. One type of switch that can be used is a relay. A relay takes in a certain voltage and current in order to switch a larger power source or load. There are electromechanical relays where switching occurs by the movement of internal mechanical parts, and solid state relays that switch using internal components like transistors and diodes. Solid state relays can be used for our project because they are much smaller in size than electromechanical relays. In addition, they are more reliable due to the fact that they have no moving parts. Having no moving parts allows the relay to function after shock, vibration or sudden impact from the user or drops to the ground.

The final advantage of solid state relays is that the switching speed is faster than that of electromechanical relays. Electromechanical relays are slower because they rely on the energizing of a magnet to perform the switching. Solid state relays, on the other hand, have transistors inside that can switch using electrical signals. Overall, solid state relays are the smallest, cheapest, and fastest relays.

Another way to switch power to the LEDs is to use a single transistor where the control signal goes into the base of the transistor to enable power. The two types of transistors considered are bipolar junction transistors (BJT) and metal-oxide semiconductor field effect transistors (MOSFET). One difference between the two transistors is that bipolar transistors need a current applied to the base of the transistor to switch the component on. MOSFETs, on the other hand, need voltage to be applied to the gate of the MOSFET in order to switch the transistor on. The issue with transistors is that they are nonlinear devices, and the slightest change in the input current and voltage will have an immediate effect on the output current and voltage.

In summary, a solid state relay will be used to switch power to the LEDs after a control signal has been received from the MCU dedicated to the lighting system. Using a solid state relay also provides stability for the output signal. What this means is that the current and voltage switched to the LEDs will not be affected by changes in the control signal. The power source for the LEDs will provide power as intended as long as the relay is activated.

5.5.12 Color of Light

We also looked at different colors of light for the LEDs. For the simplicity sake, we chose the three extremes of the visible light spectrum which are red, blue, and white LEDs. Red light has the highest wavelength in the visible light spectrum, the slowest travel time, and do not have much penetrating power. When it comes to waking up, red light does not work well for this application. Red light does not reduce melatonin levels. To reiterate, melatonin is a hormone that helps the body to relax and sleep. This type of light will most likely cause the user to sleep longer instead of waking up.

Blue light, on the other hand, has a lower wavelength, travels faster, and can penetrate deeper than red light. Blue light can be found emitting from products such liquid crystal displays (LCD) screens used for televisions, cell phone screens, and tablets. Research shows that blue light in the range of around 460 to 490 nanometers offer the best benefits when it comes to our sleep cycles. Studies also show that blue light helps the body to wake up because it decreases melatonin levels which cause our bodies to fall asleep. The LEDs used for this project will only be used to wake up the user in the morning, so it will not be an issue if melatonin is reduced. A reduction in melatonin is exactly what we need to get the user out of bed quicker.

White light is a combination of multiple colors that make up the visible light spectrum which goes from 400 to 700 nanometers. This type of light can be associated with clear LEDs tend to have a similar effect to that of blue light. However, blue light has a more profound effect on reducing melatonin and triggering the body to wake up.

5.5.13 Safety Concerns

Using artificial light sources such as LEDs can have some health effects on the user that will affect how LEDs are incorporated into this project. Energy from the light is emitted and puts undesired stress on the eyes. For one thing, LED lights can potentially cause retinal damage of the eyes. LEDs, or screens that use artificial lighting, shine light directly into the eyes of the user. According to studies, eyes are made to see in the presence of surrounding light. Based on the amount of light in the environment, the pupil adjusts to provide the best vision for the person. Looking directly at a light source is not a natural situation that the eyes are made to deal with. As a result, the eyes will deteriorate after a long period of looking directly into artificial lighting. We address these safety concerns by first limiting the amount of time that the LEDs shine on the user's face.

Studies also show that LED light, specifically blue light, can reduce melatonin levels. Although a reduction in melatonin levels is good for waking up in the morning, other health concerns can arise from the reduced melatonin. A lack of melatonin can weaken the immune system and leave the human body more susceptible to infection. Since the LED light for this project are going to be shined on the user's eyes for a short amount time (around two minutes a day), the amount of melatonin reduction will be lowered. In addition, an opaque material will be placed between the user's eyes and the LEDs to lessen some of the glare and direct exposure.

5.5.14 Power Source

There a couple of ways to power the LED lights for this project. The first way is to use power from an outlet. If a power outlet is used as a power source, we would have to attach adapter to the circuit board in order to step down 120 volts into a lower voltage that will not fry the board and burn out the LEDs. The inconvenience is that, since the LEDs will be on the face of the user, an extra cord will be attached to the LED board which could cause some discomfort while the user is trying to sleep. In addition, the user needs to make sure that the unit is plugged in every night in order to use it.

Another way to power the LEDs is to use batteries. Batteries eliminate the need for an adapter to connect to a power outlet. This gives the user a more hands-free feel. The types of batteries that will be considered are household batteries and coin cell batteries. Household batteries include AA, AAA, C, and D batteries. AAA batteries are the smallest of the household batteries. The only issue with household batteries is that they are bulky. Even AAA, will add a significant amount of weight to the LED mask on top of the populated circuit board. Yet, AAA batteries are fairly small and they can provide as much 1.5 volts per battery.

Coin cell batteries have a flat structure and much lighter than the standard household battery. The typical voltage rating of a coin cell battery is three volts, but they can have smaller voltage ratings depending on the application.

5.5.15 LED Housing

One way to house the LEDs is to 3-D print a customized pair of glasses. The glasses would most likely be made of plastic to make the glasses light weight. One advantage to making custom glasses is that we can make it look however we want. A disadvantage to using a 3-D printed housing for the LEDs is that glasses will be uncomfortable to wear while the user is sleeping. In addition, even if the user managed to sleep with the glasses on, the glasses could potentially break if the user tosses and turns throughout the night.

Next, we considered incorporating the LEDs into a sleep mask. Sleep masks are normally used to block out light from the environment while the user is trying to sleep. They are very flexible and they contour to the shape of the human face quite nicely. If we use a sleep mask as the overall housing structure for the LEDs, then we either cut out the center of the mask and a flexible printed circuit board can be placed inside. This circuit board will contain the LEDs and the other components to turn the LEDs on. The only problem with putting the LEDs in the center of the sleep mask is that a leather-based sleep mask will block out the majority of the light that is produced by the LEDs.

The other route we could go with the sleep mask is to place the LEDs and circuit board on the inside portion of the sleep mask and put a thin material over the LEDs to get rid of some of the glare. Another nice thing about sleep masks is that they are flat, so we can add padding to the make the LED mask even more comfortable for the user.

The materials for the sleep mask are important because the mask needs to be light and comfortable for the user. What we don't want is for the mask to be uncomfortable to the point where the user elects not to wear the mask at all. The mask also needs to be comprised of thin material on the portion that is closest to the user's eyes so that the LED lights can shine directly into the user's eyes and wake them up.

Some of the materials up for consideration are leather, synthetic material, cotton and mesh. Leather is a durable material that will last for a long time and has no perforations, making it perfect for blocking out light from the environment. Having no perforations can also be a bad thing because leather is not as breathable as other materials, so it would make the user's head heat up relatively quickly. Poor ventilation could cause the user to remove the mask and sleep without it. However, cleaning leather only requires a damp cloth, which is very convenient. Another disadvantage of using pure leather is that leather is not cheap.

The second material that we can use for the mask is synthetic material. Synthetic material is not as expensive as pure leather and it is lighter than leather as well. Ventilation is still an issue but synthetic leather still does a great job of shielding against light in the environment. Third, cotton can be used for the mask. Cotton tends to be a little bit thicker than materials such as leather and mesh. In addition, cotton is somewhat breathable yet it still retains a fair amount of heat which could be uncomfortable for the user during the night. The last material we considered is mesh. Some advantages to using mesh for the sleep mask is that mesh has excellent ventilation and it is lightweight. The ventilation aspect of using mesh is very appealing seeing as users will not have to worry about heat accumulating on their faces. The only drawback to mesh is that light can penetrate through mesh easily unless layers of mesh are used.

In summary, this the LEDs should be incorporated into a sleep mask instead of using a custom 3-D printed pair of glasses to save on overall costs and reduce the production time. Materials with poor ventilation will be used in small quantities and a combination of materials should be used to ensure that the mask is able to block out light from the environment and allow light to shine into the user's eyes. For this project, we will most likely use synthetic leather for the outside of the mask and cover the inside of the mask with mesh and place the LED circuitry in between.

5.5.16 Photodetectors

The first photo sensor option is called the Adafruit TSL2560/TSL2561 Lux light sensor. This sensor converts light energy into a digital signal. It can also measure infrared, visible light and the full light spectrum. The Adafruit sensor includes a I2C digital interface and it can be used with any microprocessor. The advantage of this sensor is that it converts the light to a format that can be easily collected by a microcontroller. The cost of each Adafruit sensor is \$5.95.

Two different photoresistors were considered. The GL5528 photoresistor has a power dissipation of 100 mW and the cost of \$0.50 per resistor. On the other hand, the KE-10720 light-dependent resistor has a maximum power dissipation of 35 mW and costs \$0.79 per resistor. Both photoresistors have good power dissipation and fairly low price points, however there are some disadvantages to using them. For one thing, photoresistors do not produce voltage. Another drawback is that photoresistors have a narrow range compared to a phototransistor or photodiode.

The final two options are phototransistors. The TCRT1000 includes an IR LED and phototransistor with a peak wavelength of 950 nm. It costs \$0.80 per sensor and has dimensions of 7x4x2.5 mm. The TCRT1000 dissipates 200 mW and it is a fairly big component. Another option is the EL-PT908-7B phototransistor. Table 11 lists all the detectors considered in this project.

Table 11 Light Detectors Comparison

Device	Sensor type	Peak Wavelength	Operating Temp	Power Dissipation	Dimensions	Price
GL5528	Photoresistor	540 nm	-30 to +70 degrees Celsius	100 mW	5.04x3.81x2.4 mm	\$0.50
KE-10720	Light dependent resistor	540 nm	-30 to +60 degrees Celsius	35 mW	5.3x4.6x3.5 mm	\$0.79
TCRT1000	Phototransistor	950 nm	-40 to +85 degrees Celsius	200 mW	7x4x2.5 mm	\$0.80
EL-PT908-7B	Phototransistor	860 nm	-25 to +85 degrees Celsius	75 mW	5.7x4.5x1.5 mm	\$0.45

5.6 Cooling

There are many liquid pumps on the market with different flow rates and operating specifications. For the cooling system, the pump needs to be efficient enough where it is not wasting energy but fast enough where the liquid will be able to cool down the user quickly. Table 12 shows the different pumps that were researched and compared in order to come up with the best unit for the cooling system.

Table 12 Liquid Pump Comparison

Name	Price	Flow Rate	Wattage	Operating Voltage (V)
Light Object Mini Pump	15.50	3.6L/min	500mA max	12
ShurFlo Nautilus Single-Fixture	32.02	3.79L/min	2.5A max	12
Mini DC 12V Electric Centrifugal Water Pump	32.98	6.5L/min	500mA max	12
Docooler Mini Pump	11.69	4L/min	4.8W	12

The light object mini pump is one of the first products to take in consideration in the cooling system. The pump is a submersible device that is quiet when in use and features a strong flow rate. However, the pump needs to have water flow at

all times or else the pump will fail. Furthermore, the pump can only be ran with water which provides further limitations on the types of liquid being used. The ShurFlo single fixture pump also was taken into consideration however it is designed for intermittent applications. In the event that the cooling system needs to run consistently for multiple hours, this pump would fail. The Mini DC 12V Electric Centrifugal water pump was also under consideration due to its high flow rate at 6.5L/min. This puts this pump at the highest flow rate compared to all of the other products under consideration. However, the price of this pump was significantly higher than some of the cheaper pumps that were just as effective for this cooling system application. Therefore, the Docooler Mini Pump was the ultimate decision for the pump to be used in the cooling application. The high flow rate at 4L/min was ample enough to provide water through the cooling lines and the affordable price made this pump desirable for the system.

5.7 Microcontrollers

The Knight Nite system depends on microcontrollers (MCU) to transform and normalize sensor data, control peripheral devices, and output data to the visualization and control platform (VCU). The design criteria for microcontroller selection are power consumption, floating point operations, and communication interfaces.

Of primary consideration, the microcontroller must be able to perform floating point arithmetic calculations and communicate via Universal Serial Bus (USB). The microcontroller power requirements must be relatively low and scalable based on processor performance requirements. Further considerations include but are not limited to cost per unit, availability of development boards, and programming environment. The number of general-purpose input outputs (GPIOs) on most commercially available MCUs more than exceeds the number of sensor inputs and device outputs of Knight Nite. Furthermore, there are few analog-to-digital conversions requiring relatively low sample rates. Therefore, A/D conversion is a low design priority.

The lowest priority feature that is still a consideration is community support. To ease design and development of Knight Nite, an active hobbyist community using the selected microcontroller is a good feature. In general, hobbyists tend to use simpler designs and have a willingness to assist others using their preferred microcontroller.

A microcontroller shall be selected based on a best fit of the high priority design criteria, cost considerations, and ease of programming. Most commercially available MCUs provide development boards and programming environments in the C programming language. In general, Knight Nite assumes commercial off-the-shelf processors with floating point units more than exceed the data processing requirements of the project.

The programming requirements of Knight Nite assume several microcontrollers acting independently to acquire data, do data processing, do control of devices, and transmit normalized data to the visualization and control platform. In practical terms, a singular instance of Knight Nite system microcontroller must read data from a sensor. Next, it must process and transmit the received data over USB. Finally, it must perform a control algorithm update and transmit a control signal to a device. Considering the relatively low programming requirements, the Knight Nite program is assumed not to exceed the memory capacity of the microcontrollers under consideration.

The availability of low cost development and evaluation boards is considered a high priority feature. A development board will allow the Knight Nite team to develop and test functions of each subsystem. Both the implementation of programs and circuitry is simplified if a development board can be used during the implementation phase of the project. Table 13 below describes the features and capabilities of the Knight Nite microcontroller.

Table 13 Microcontroller Features

1. Floating Point Unit	6. Cost Per Unit
2. Power Consumption	7. CPU Frequency
3. USB Connectivity	8. SRAM Size
4. Availability of Development Boards	9. Programming Environment
5. Number of GPIOs	10. Community Support

The top four capabilities floating point unit, power consumption, USB connectivity, and availability of development boards shall be the bottom-line deciding factors in selecting a microcontroller for Knight Nite.

Three families of microcontroller are considered based on their popularity in the market at the time of this comparison: Atmel SAM G MCUs, STMicroelectronics STM32F4x MCUs, and Texas Instruments Tiva C Series MCUs. For the purposes of this comparison, a 32-bit MCU is picked from each family and the set of features of each evaluated. An analysis shall be conducted with the result being a microcontroller selection. The microcontroller selection shall be based on the best fit to the set of Knight Nite features and capabilities. Unless otherwise stated, each microprocessor is a Quad Flat Package with “gull wing” leads extending from each side. The microprocessors surveyed have a minimum number of leads, typically sixty-four or less.

The Texas Instruments Tiva C TM4C123GH6PM is a 32-bit microcontroller based on the ARM Cortex-M4 family of processors. The max operating frequency of this MCU is 80 MHz and the Cortex-M4 contains a floating-point unit capable of single-precision operations. The Tiva C series in general attempts to combine low cost, low power, and relatively high performance microcontroller features. In particular, the Cortex-M4 ARM processors benefit from the many ARM development tools and large community support. Table 14 lists the features of the Tiva C TM4C123GH6PM used in the evaluation of microprocessor selection. The pinout for the TM4C123GH6PM is shown below in Figure 10.

Table 14 TM4C123GH6PM Features

FEATURE	DESCRIPTION
Core	ARM Cortex-M4F processor core
Performance	80-MHz frequency
Flash Size	256 KB
SRAM Size	32 KB
General Purpose I/Os	43 5V tolerant
Analog-to-Digital Converter	2 12-bit ADC units, Max 1Msps Per Unit, 12 channels
Communication Interfaces	8 UART, 6 I2C, 4 SPI
USB	USB 2.0 Host/Device/OTG + PHY
Power Consumption (active)	3.3v, max 44.2 mA

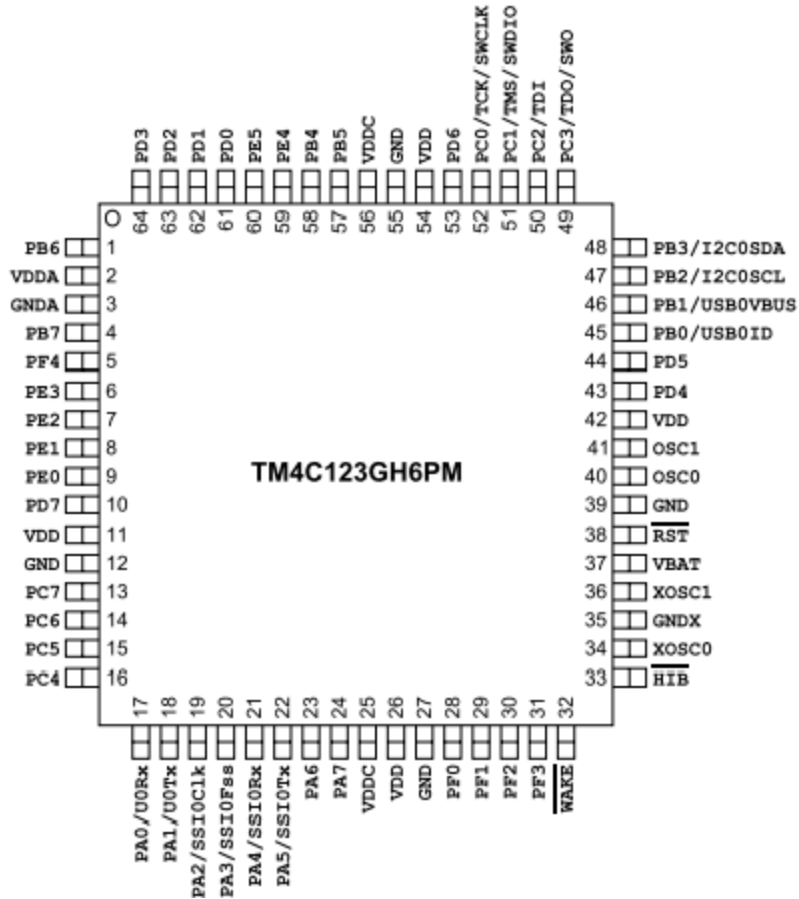

Figure 10 STM4C123GH6PM Pinout

The STMicroelectronics STM32F401RB is a 32-bit microcontroller based on the ARM Cortex M4 family of microprocessors. The max operating frequency of the MCU is 84 MHz and contains a floating point unit capable of single-precision operations. Additionally, the MCU implements a full set of DSP instructions and memory protection unit. As in the case of the Texas Instruments microcontroller, the STM32F401RB benefits from the full range ARM development tools. STMicroelectronics also provides a full set of development tools, an integrated development environment, proprietary debugging interface ST-LINK/V2, and support for C/C++/C# application programming languages. The STM32F401x series is intended to be a good mix of low power, high performance, and low cost. It features a full complement of enhanced I/Os and peripheral support including USB connectivity. STMicroelectronics produces the 32F401CDISCOVERY Discovery kit which is essentially a development board featuring many peripheral devices. The ST-LINK/V2 debugger may be a necessary development item and should be considered in cost factors. Table 15 lists the features of the STM32F401RB used in the evaluation of microprocessor selection. The pinout for the STM32F401RB is shown below in **Figure 11**.

Table 15 STM32F401RB Features

FEATURE	DESCRIPTION
Core	ARM Cortex-M4 processor core
Performance	84-MHz frequency
Flash Size	128 KB
SRAM Size	64 KB
General Purpose I/Os	Up to 81 ports all 5V tolerant
Analog-to-Digital Converter	1 12-bit ADC units, Max 2.4MSPS, 16 channels
Communication Interfaces	3 USARTS, 3 I2C, 4 SPI
USB	USB 2.0 full-speed device/host/OTG controller with on-chip PHY
Power Consumption (run mode)	1.7/1.8V up to 3.6V, max 35 mA

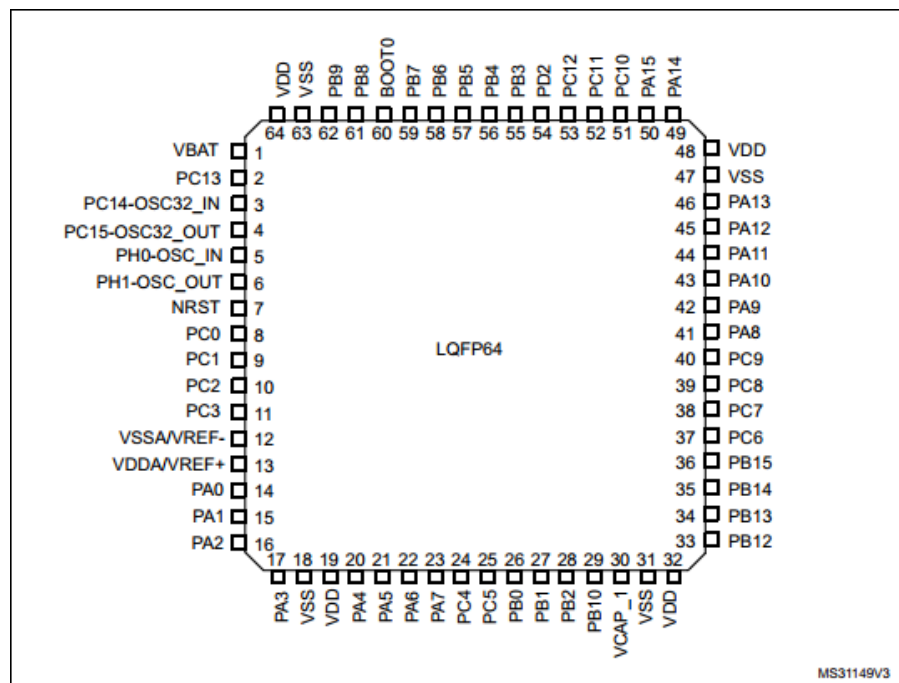

Figure 11 Permission applied for from STMicroelectronics

The Atmel SMART SAM G54 is a 32-bit microcontroller with floating point unit based on the Cortex-M4 family of processors. The max operating frequency of this MCU is 96 MHz and attempts to achieve a good mix of low power consumption, dynamic performance, and broad set of peripherals. As with the other microcontroller selections, there is a rich ecosystem of development tools both for the ARM processor and SMART SAM G54 MCU. Atmel provides their own integrated development environment, support for the C language, and proprietary debugger. The SMART SAM G54 is a 49-ball WLCSP form factor. Table 16 lists the features of the Atmel SMART SAM G54 used in the evaluation of microprocessor selection. The pinout for the SMART SAM G54 is shown below in Figure 12.

Table 16 SMART SAM G54 Features

FEATURE	DESCRIPTION
Core	ARM Cortex-M4 processor core
Performance	96-MHz frequency
Flash Size	512 KB
SRAM Size	96 KB
General Purpose I/Os	38
Analog-to-Digital Converter	1 12-bit ADC units, Max 800 kSPS, 8 channels
Communication Interfaces	3 USARTS, 3 I2C, 1 SPI
USB	None
Power Consumption (run mode)	1.62 up to 3.45V, max 35.1 mA

A1	PA9
A2	GND
A3	PA24
A4	PB8/XOUT
A5	PB9/XIN
A6	PB4
A7	VDDIO
B1	PB11
B2	PB5
B3	PB7
B4	PA2
B5	JTAGSEL
B6	NRST
B7	PB12

C1	VDDCORE
C2	PA11
C3	PA12
C4	PB6
C5	PA4
C6	PA3
C7	PA0
D1	PA13
D2	PB3/AD7
D3	PB1/AD5
D4	PB10
D5	PA1
D6	PA5
D7	VDDCORE

E1	PB2/AD6
E2	PB0/AD4
E3	PA18/AD1
E4	PA14
E5	PA10
E6	TST
E7	PA7/XIN32
F1	PA20/AD3
F2	PA19/AD2
F3	PA17/AD0
F4	PA21
F5	PA23
F6	PA16
F7	PA8/XOUT32

Figure 12 SMART SAM G54 Pinout (Permission applied for from Atmel)

Based on the microcontroller selection criteria identified in the previous section, and the set of microcontrollers surveyed, both the Texas Instruments and STMicroelectronics microcontrollers fulfill the criteria. The Atmel MCU does not support USB and another comparable Atmel MCU based on the ARM processor could not be found meeting the Knight Nite criteria. Texas Instruments and STMicroelectronics both provide development tools, debuggers, and detailed documentation for their microcontrollers. On comparison, the STM32F401RB uses less power than the TM4C123GH6PM and is a lower cost for the individual component and development board. The STMicroelectronics development tools additionally allow the use of higher level languages, such as Java and C#, to develop applications for the STM32. Based on those considerations, the STM32F401RB will be the microcontroller for Knight Nite.

6. User Interface

The Knight Nite user interface shall be a set of graphic user interface components displayed on a handheld computing device. Analysis of commodity handheld computing devices and the wide variety of commercial graphical user interface software suggests engineering either is far outside the scope of this project. Therefore, the Knight Nite team has chosen to use a smartphone platform to host the supervisory control, data transform and storage, and presentation software. Each Knight Nite subsystem shall have an MCU programmed to do sensor data acquisition, process control, and transmission of normalized sensor data to the visualization and control platform (VCU). The VCU

is a smartphone hosting software to present a graphical user interface to the Knight Nite system. The smartphone software shall read sensor data from a USB interface, transform data, and present data in engineering units on strip charts. The smartphone software shall additionally provide an interface to display status of the system and control over each subsystem.

The choice to utilize a smartphone platform has many value added benefits. For example, all of the major mobile operating systems provide an application programming environment with accompanying integrated development tools. The operating systems further provide graphical user interface application libraries and user interface style guides. Programming environments are generally in a variety of higher level object oriented languages such as Java. The programming environments also provide various mechanisms to statically and dynamically debug applications. The application programming environments additionally provide libraries to read data from USB, do common mathematical transforms on data, and store data on the device.

In general, the Knight Nite development team will adhere to conventional user interface design principles. First, and most important, the user interface must present data in a concise, logical, and intuitive manner. The control functions must be obvious in purpose and clearly partitioned from data presentation. The user interface will additionally clearly display status of the system. Sleep activity of the user will be plotted versus time with the user's sleep phases inferred from motion and temperature. The user shall additionally be able to access past sleep activity.

The smartphone shall host a commercially available mobile operating system. The operating system chosen affects which application programming environment is available to the Knight Nite development team. The choice of programming environment affects total software development and debug time as well as the look and feel of the Knight Nite application. Described in the following sections is a brief survey of each mobile operating system considered by the Knight Nite team.

6.1 Android

Android is a mobile operating system developed and maintained by Google. The operating system is based around on open source Linux kernel. Additionally, Google releases Android source code under open source licenses. The open nature of Android has motivated a large community of developers to maintain and develop Android for many handheld devices including smartphones, tablets, and media devices. Android dominates the market for tablets and smartphones [15].

The Android OS is a popular choice for device manufacturers who frequently utilize open source software to host proprietary device drivers and applications. Development tools for Android are free and abundant in variety of function. The open source and extensible development environment Eclipse is available with Android graphical user interface plugins and Android application programming library support. Furthermore, Eclipse makes developing Android GUI applications simpler by providing integrated debug and simulation of Android capable devices.

The official development language of Android is the Java programming language. Java is a high level fully object oriented programming language and fully supported by the Eclipse integrated development environment. Java is a widely known and highly utilized language in commercial and academic environments. The Knight Nite software development team has professional experience with Java in a commercial setting for mobile devices. To aid in the tools analysis, Table 17 describes pros and cons of choosing Android as the Knight Nite application platform.

Table 17 Android Comparison

Pros	Cons
Open source free development tools	Locked into Android platforms
Eclipse integrated development environment	Availability of free cross platform development tools
Java programming language	
Large smartphone market share	
Large and active commercial and hobbyist community	
Prior experience with Java	

6.2 iOS

iOS is a mobile operating system for the Apple line of handheld computing devices. The most popular iOS platform is the Apple iPhone series of smartphones. iOS is second only to Android in market share and the two combined account for approximately ninety-eight percent of the smartphone market. iOS and the development tools for iOS are proprietary products of Apple. Apple requires developers to purchase an annual service and adhere to Apple's software licensing policies and user interface style guide. Furthermore, the cost

of an iPhone or iPad development platform is prohibitive ranging in the hundreds of dollars. Apple provides the Xcode integrated development environment hosting the Objective-C programming language. Objective-C is an object oriented superset of the C programming language primarily supported only on Apple platforms. The Knight Nite software development team has no experience with Objective-C and no experience with the Xcode IDE. To aid in the tools analysis, Table 18 describes pros and cons of choosing iOS as the Knight Nite application platform.

Table 18 iOS Comparison

Pros	Cons
Large smartphone market share	Locked into Apple platforms
	High development tool cost
	Proprietary licensing
	Developer learning curve for Xcode IDE and Objective-C language

6.3 Window 10 Mobile

Windows 10 Mobile is a closed source and proprietary operating system developed and maintained by Microsoft. Windows 10 Mobile is the third largest installed mobile OS for smartphones, tablets, and media devices. Windows 10 Mobile utilizes a portable graphical user interface library called Windows 10 Metro. Applications developed on Windows 10 Mobile promise to be portable to all Windows platforms including PCs and supporting a command look and feel. Development for Windows 10 Mobile is done using Microsoft Visual Studio integrated development environment and the C# programming language and the .NET framework. Visual Studio incorporates many powerful programming tools including integrated support for debugging and simulation of Windows 10 Mobile devices. Additionally, Visual Studio has integrated development of Windows 10 Metro graphical user interfaces. Microsoft provides a community version of Visual Studio for free that is supported on the Universal Windows Platform framework which promises support across all Windows devices. C# is a high level fully object oriented programming competing directly with the Java programming language. The Knight Nite development team has previous experience programming for Windows devices and using the C# programming language. To aid in the tools analysis, Table 19 describes pros and cons of choosing Windows 10 Mobile as the Knight Nite application platform.

Table 19 Windows 10 Mobile Comparison

Pros	Cons
Free development tools	Locked into Windows platforms
Visual Studio integrated development environment	Availability of low cost cross platform development tools
C# programming language	Proprietary licensing
Prior experience with C#	Small smartphone market share
Large amount of well-maintained documentation	

The current trend in technology indicates over two-thirds of Americans own a smartphone and ownership is only increasing over time. [17]. This fact accompanied by the wide range of available application programming environments makes the choice of smartphone as host for the Knight Nite visualization and control software obvious. Choosing a smartphone and mobile operating system with large market share provides Knight Nite with a built-in user base as a product. Scaling Knight Nite production to consumer levels will require only optimization of the hardware design and implementation. The software design can remain relatively stable and portable across many smartphones and tablets.

Android and iOS are the two clear choices based on market share. Though Windows 10 Mobile provides powerful and free development tools, the market share for Windows Universal Platforms is not on the same order as Android and iOS. iOS requires the Knight Nite development team to pay for software tools and development hardware. Additionally, the Xcode IDE, Objective-C programming language, and iOS application libraries will require a substantial learning curve and time investment for the software development team. The clear choice for the Knight Nite VCU application is a smartphone running Android, the Eclipse IDE, and the Java programming language.

6.4 Data Visualization

Data visualization is an important concern of the Knight Nite VCU application. Data must be presented to the user in a compact format that is easy to understand and act on. Typically, in scientific and commercial applications, near real-time data is presented in the form of dynamically updated graphs called strip charts. The Knight Nite application shall have the capability to display sleep

activity and sensor data with static graphs and dynamic graphs updated periodically. The Android application programming environment must support the graphical user interface components necessary to graph data. Custom building graphing software is outside the scope of this project. Thus, the following analysis compares software graphing packages and identifies a choice for the Knight Nite VCU application.

6.4.1 AndroidPlot

AndroidPlot is a free and open source data visualization software package for Android that provides both static and dynamic plots of data. The AndroidPlot website provides example code, documentation, and a link to the actively maintained source code in Github. Figure 13 demonstrates an XY plot for an Android smartphone. Note: Permission applied for.

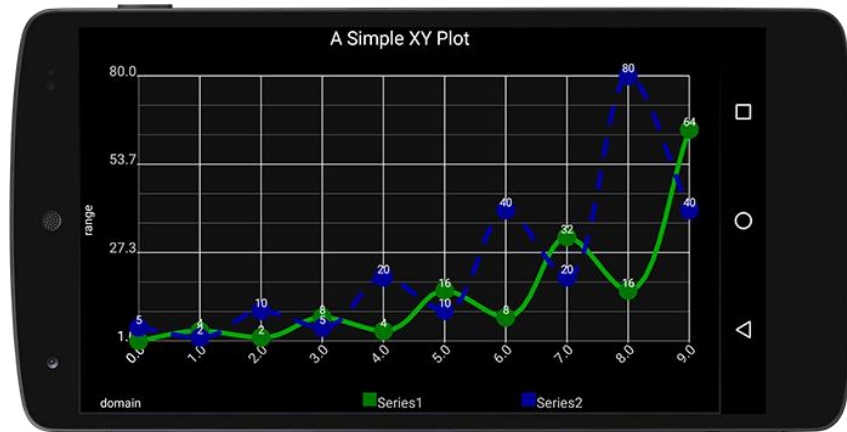

Figure 13 AndroidPlot

6.4.2 MPAndroid Chart

MPAndroid Chart is a free and open source data visualization software package provides aesthetically pleasing static graphs of data. An important consideration for Knight Nite is whether MPAndroid Chart can provide dynamic graphs at an acceptable update rate. An acceptable update rate for Knight Nite sensor data is 10 Hertz. MPAndroid Chart does provide dual Y axis support for graphing multiple data sets on the same graph. Additionally, the user documentation states smooth scrolling for up to 30,000 data points on a line chart. The MPAndroid Chart website provides documentation and example code. Figure 14 shows an example of a line chart plotting sine function. Note permission applied for.

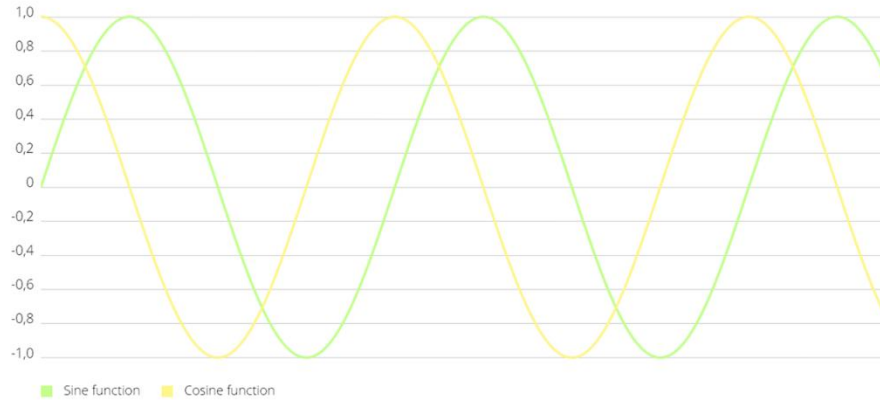

Figure 14MPAndroidChart Line chart

6.4.3 GraphView

GraphView is a closed source freely available graphing software package used to programmatically create custom graphs. GraphView explicitly supports updating graphs with near real time data. As in the other cases, the GraphView website provides documentation and example code. Figure 15 shows an example scrolling XY plot provided by GraphView. Note permission applied for.

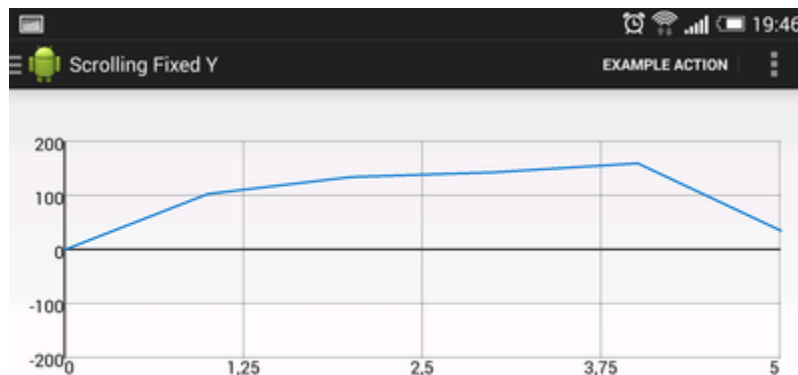

Figure 15GraphView scrolling XY plot

The highest priority consideration for choosing a graphing software package is dynamic graphing. Without directly evaluating each package, an analysis can only consider the available documentation and community support. Furthermore, the package must be able to sustain indefinite dynamic updates to the graph at 10 hertz. The AndroidPlot documentation and supporting demonstrations and example code provide the most confidence to meet the Knight Nite graphing requirements. However, the software development team must directly evaluate AndroidPlot during development to confirm the package can meet the

requirement. It should be noted none of the analyzed graphing packages provide Eclipse IDE integration and must be configured programmatically.

7. Power

The design process for the power systems in Knight Nite needs several considerations before being implemented. While the system needs to be efficient and cost effective, there are several ABET standards and constraints when it comes to the safety of the design. Because most of the power supplies on the market already meet the safety requirements, this was taken highly into consideration for the final build of materials for the power system.

Some of the subsystems such as the cooling subsystem and its mechanical water pump feature takes in only DC power. These systems can be powered by a simple battery or utilize a simple wall outlet power supply with an AC to DC converter. Since all of the subsystems have their own printed circuit boards and microcontrollers, it is imperative that the power systems need to be able to support these microcontroller systems efficiently without overpowering them.

When dealing with power, safety is critical in the design and implementation of Knight Nite. The risk of electrical shock can be lethal and present if certain preventative measures and procedures are not laid out before or taken seriously. Therefore, it is important that none of the group members are working alone during portions of testing power for the project. There is also the possibility of a fire when designing or handling a power supply. If the schematics and designs are not implemented properly some components on the printed circuit boards may fry from an overload of voltage and current. In order to prevent the occurrence of a possible fire, the active and passive components on the printed circuit board will need to be placed safe distances from each other using the cad program Eagle. Therefore, prevents the whole printed circuit board from burning in the event that only 1 component burns.

Because Knight Nite is still in its first design phase, it is important that the components that are used for the testing stage are cheap so that if pieces of the project were to burn and be destroyed, they are easily replaceable and do not become a financial burden for the team. While testing the power supply system with the printed circuit boards and other subsystem components, it was necessary to monitor the amount of heat that was coming from the components to make sure that they are able to withstand the full 8 hours of sleep during one sleep cycle. Necessary changes are going to be made further down the implementation process once there are constraints that come up with the power systems and the implementation with the subsystems.

The power system and subsystems will need to be enclosed in a clean case that will not cause a fire hazard for the entire system. Knight Nite is a product that the

user will be able to wear on their head in order to receive treatments for their sleep disorder. Because the user is wearing this electrical device, it is important that the device is not only comfortable but safe for the user to have on their head for a long period of time.

Implementing the power supply over the printed circuit board design brings up several considerations to address. First off, the resistance of the traces on the PCB affect the power requirements and maximum current requirements as well. In order to fully test and diagnose this problem, a full understanding of how to measure and analyze the resistance of these components will be needed.

7.1 Power Configuration

There are many configurations for power that can be used for the implementation portion of Knight Nite. Determining the different voltage and current types and selecting the appropriate configuration. Most of the power supply configurations have the basic layout when transforming power from a wall outlet to a usable DC power source as seen in Figure 16.

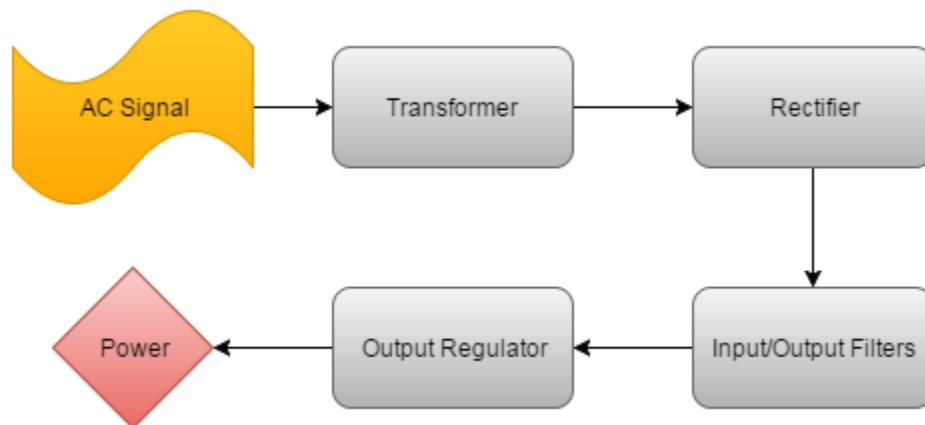

Figure 16 Power Supply Block Diagram

Most power supplies have similar universal stages they go through in order to convert power into something usable. The first stage of a power supply involves a transformer which can either step up/down the voltage coming out of the power source. The need for a transformer is necessary in order to separate the power supply system from the actual power source. The second stage involves a rectifier that converts the alternating current coming out of a wall socket to a usable DC current. This type of voltage is more favorable for the microcontroller system that will be implemented with Knight Nite. The direct current will then need to be put through input filters in order to bring the current down to a more usable signal. After this, the signal goes through an output regulator that keeps the signal steady regardless of sudden changes in the current or input voltage from the wall sockets.

These different topologies that are offered throughout the market create different voltage and current signals that will affect the design of Knight Nite. By researching and gathering data of the best topology of power to use with the microcontroller systems, the implementation process will run smoother and be more efficient.

When researching into the different power supplies and the types of AC to DC converters used, a fly back process was considered for one of the power topologies in Knight Nite. Due to its isolated power conversion design, this power supply system topology proves to be safer for the user and the system in case any problems were to arise with the power system. However there are limitations to a fly back topology for the power supply system. One limitation includes the power supply voltage being run at a lower bandwidth due to a zero being present in the right half plane of the rectifier. This can be modeled through a linear control system showing the instability of the power supply at higher bandwidths.

For a DC to DC step up or down power supply converter, a Buck system was considered in the design process of Knight Nite's power supply unit. This is also known as a boost topology. Since the microcontrollers on the printed circuit boards will provide most of the power to the sensors by the USB, a boost converter will most likely be implemented for the major subsystems. Therefore, this power systems will be isolated from the other power supplies coming out of a wall socket to increase the safety constraints for the user. This can be done by implementing a transformer that will be able to isolate the power that is coming into the microcontroller.

Both of these power topologies offer great benefits to the design of Knight Nite. However, the designs of a buck and fly back power topology needs to have constraints that include low cost and provide efficiency which will not overpower the entire system. Another limitation of the power systems is the size of the power supply. Since Knight Nite will have the user interface away from the user during sleep, the power supply does not have to be small. However, it cannot be so big that it takes away from the practicality of the entire system. Therefore, finding a portable sized device for the power supply that will meet all of the specifications for the microcontroller systems and all other major subsystems will be taken into consideration before deciding on what is best to use.

7.1.1 AC Power

The base power supply for Knight Nite will come from a standard American wall outlet outputting roughly 120 volts. This power supply system will be created using the CAD software Web bench created by Texas Instruments. This power supply will provide power for the all the subsystems that need an isolated power source such as the pump for the cooling system. Since these specific

subsystems need power beyond the voltage signals supplied by the USB system, there needs to be a power supply utilizing an AC to DC converter.

There were many different isolated fly back topologies that were suggested in the Web bench program. Some offered higher efficiency while lacking in the footprint size category. Other pulse width modulator controllers offered high efficiency while being limited in the regulation of the voltage signal. Furthermore, it was important to take into consideration the constraints and limitations of the power systems before choosing the best controller to supply power from a standard wall outlet.

7.1.2 Fly Back Controllers

Table 20 shows the research process of different types of controllers to use for the power supply systems. There were 3 made by Texas Instruments that stood out the most. The UCC38C42 is an opto-coupler feedback controller that runs at lower operating currents of approximately 2.3mA. Furthermore, this controller can operate at higher frequencies up to 1MHz and has low start up currents. The UCC38C42 also features a fast current sense to output delay of 35 ns. Similar to this controller, the UCC28910 was also considered in the design process of the power supply. Although it features lower efficiency percentages than the previous controller, and it shines through its constant voltage and current regulation using the 700v powered FET. Furthermore, there are built in control algorithms working with switching frequency and current modulation that allow the UCC28910 to compute quickly. There are also built in protection features such as a thermal shutdown and an over-voltage shutdown. Figure 17 shows the functional block diagram of the UCC28700. This schematic shows the low level processes of the switching management and control algorithms that goes into this flyback topology. Note: Permission applied for.

Table 20 Fly back Controllers Comparison

Name	UCC38C42	UCC28910	UCC28700
Manufacturer	Texas Instruments	Texas Instruments	Texas Instruments
Design	Opto-coupler Feedback	High Voltage Flyback Switcher	Isolated Flyback
Efficiency	84%	76%	81%
Footprint	1954mm ²	926mm ²	787mm ²
BOM # of Parts	55	27	29
Topology	Flyback	Flyback	Flyback

Frequency	99kHz	105kHz	0 kHz
Current Output Max	20.0A	2.0A	4.0A

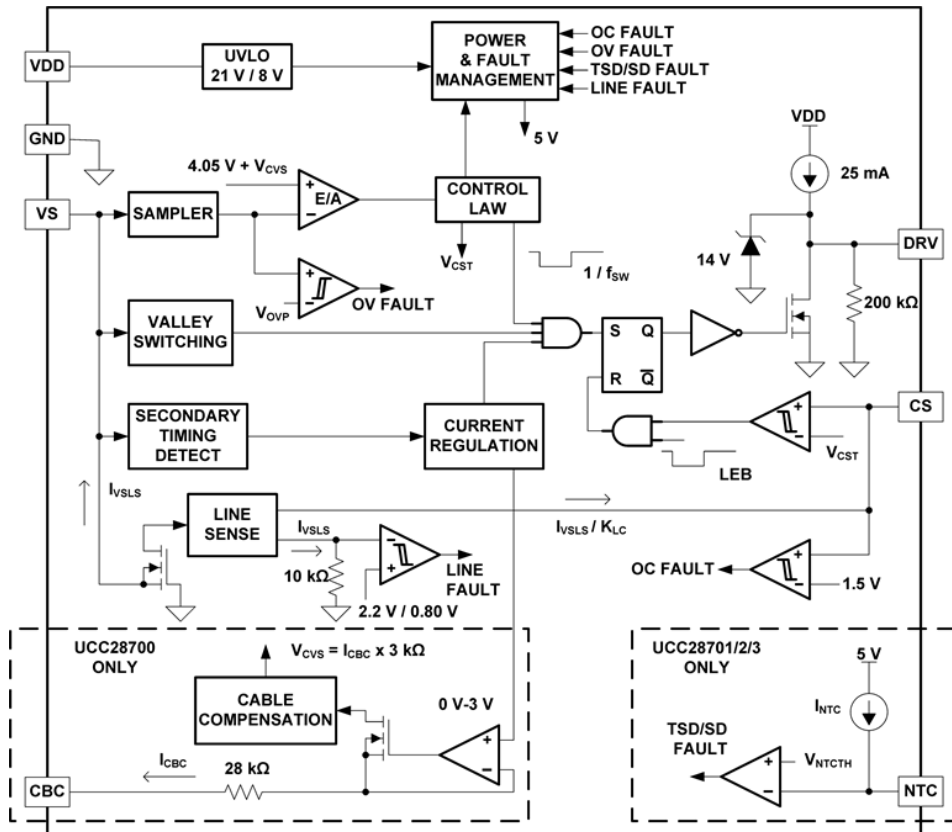

Figure 17 UCC28700 Functional Block Diagram

Figure 18 shows the typical schematic of the UCC28700 provided by Texas Instruments. This simple AC to DC converter can be implemented on the Eagle cad software and will be later tested to ensure that this power supply system meets the demands and requirements of the major subsystems.

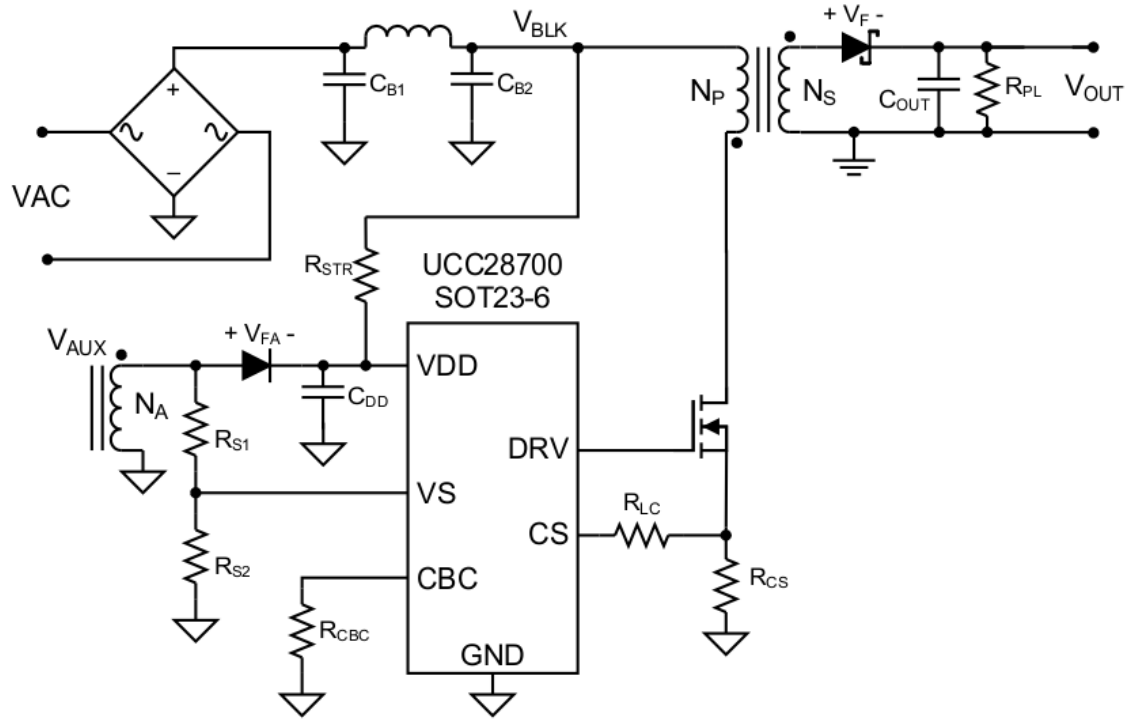

Figure 18 UCC27800 Application Schematic

7.1.3 DC Power

The DC power supply will use a buck converter/integrated switch method that will step up or down the voltage signal in order to be used for the major subsystems. There were several integrated switches that Texas Instruments makes that were considered in the design and implementation for the power system. Many buck converters offered different types of output efficiencies as well as different footprint sizes on the printed circuit boards. The schematics for the DC power printed circuit board layout was implemented in the CAD software Webench by Texas instruments. This program allowed for direct comparison of converters and integrated switches to help make the best choice for the buck converter used for the power supply system.

7.1.4 Buck Converters

There were 3 major buck converter switches that were considered in the design process for the DC power supply system. The LM25010 is a step down regulator and was one of the first buck converters that was considered due to its simple design. However, it lacks in the efficiency category at only 67%. The LM3151 series was also taken into consideration for this power supply design. It is a simple switcher and has the least amount of parts compared to the other 2 buck

converters. Although this switcher is efficient, it is too overpowered for the type of power supply system needed for Knight Nite. Therefore, the TPS54336A is the best choice which features a high efficiency and a current output maximum of 3%. Table 21 shows the comparison of all 3 buck converters that were considered in this design.

Table 21 Buck Converters Comparison

Name	TPS54336A	LM3151-3.3	LM25010
Manufacturer	Texas Instruments	Texas Instruments	Texas Instruments
Design	Monolithic Buck Converter	Simple Switcher	Step Down Regulator
Efficiency	87%	94%	67%
Footprint	214mm ²	1113mm ²	230mm ²
BOM # of Parts	12	10	14
Topology	Buck	Buck	Buck
Frequency	340kHz	251kHz	542kHz
Current Output Max	3.0A	12.0A	1.0A

Figure 19 shows the functional diagram of the TPS54336A with the mock DC power supply system. The schematic given by Texas Instruments shows the low level components and what operations need to be carried out in the design. It features a Power logic unit which controls the entire system as well as a shutdown logic unit for the protection of the buck converter itself.

Figure 20 shows the typical application schematic of the TPS54336A as given by Texas instruments. This is the general schematic layout that will be implemented in the Eagle cad software. After the printed circuit board is developed, further testing will be carried out to make sure that the buck converter provides the appropriate amount of voltage and current for the major subsystems.

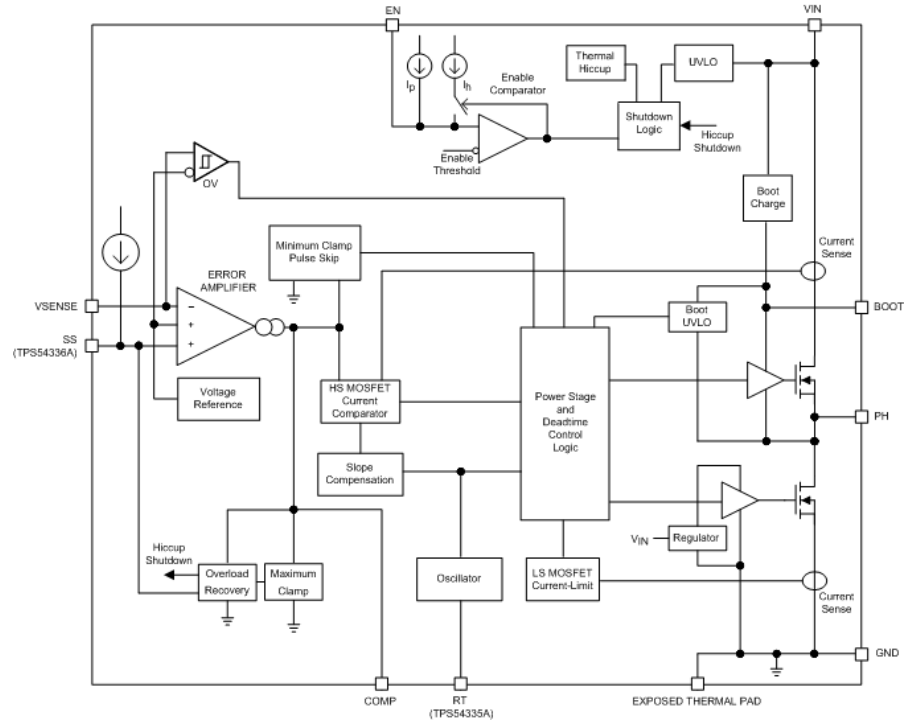

Figure 19 TPS54336A Functional Block Diagram

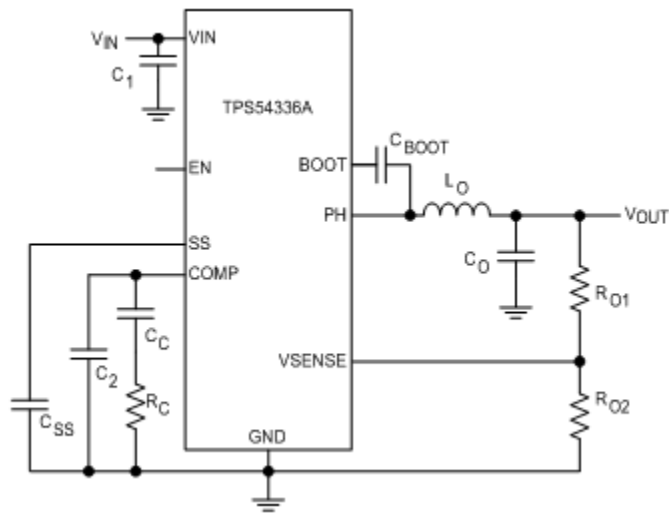

Figure 20 TPS54336A Application Schematic

7.1.5 Types of Batteries

Battery Selection specifications that were scrutinized was the internal resistance for the last two remaining options, one can clearly see that the Li-Po battery has much higher internal resistance, which means that less current flow at the output. Nevertheless, the table also shows that the capacity of the Li-Po is much higher; because of this the internal resistance can be considered negligible.

The energy density is another reason why the lithium-polymer is the best choice to integrate into the project. Furthermore, lithium polymer batteries are far more efficient and longer lasting. Because of its many advantages when compared to other battery options, the lithium polymer battery was chosen for inclusion into the baby monitor system.

Because the power supply that will be used is rated for much higher voltages than the rated voltages for a majority of the parts that will be used for the project, it is apparent that an additional design consideration will be needed to maintain the voltage in the circuits at a manageable level for the components.

8. ABET Standards & Constraints

Design standards used in this project were searched on nssn.org. Table 22 lists the different standards used. The standards for Knight Nite address some important factors such as USB serial communication, programming languages to process and visualize data, lighting and sound. Table 22 displays the standards that apply to the design of this project.

Table 22 Design Standards

Standard Number	Scope	Title
IEC 62680-1 Ed. 1.0 b:2013	USB	Universal serial bus interfaces for data and power - Part 1: Universal serial bus specification, revision 2.0
IEC 62680-2 Ed. 1.0 b:2013	USB	Universal serial bus interfaces for data and power - Part 2: Universal serial bus - Micro-USB cables and connectors specification, revision 1.0
IEC 60747-5-6 Ed. 1.0 b:2016	LED	Semiconductor devices - Part 5-6: Optoelectronic devices - Light emitting diodes
IEC 60268-4 Ed. 5.0 b:2014	Microphone	Sound system equipment - Part 4: Microphones
ISO/IEC 30106-2:2016	JAVA	Information technology - Object oriented BioAPI - Part 2: Java implementation
ISO/IEC 9899:2011	C Programming	Information technology - Programming languages - C

8.1 Design Constraints

There are some design constraints that we had to think about when we were developing Knight Nite. The most important constraints were economic, ethical, safety, and timing.

8.1.1 Economic

An economic constraint is a restriction to a certain project or product by financial means. This could be a budget or a reason why a product is not selling like it should. The economic limitation on our project, Knight Nite, is mostly monetary. As is discussed in the budget and finance section at the end of this paper, we were not sponsored by any company we are responsible for 100% of our estimated budget.

8.1.2 Ethical

Another constraint we have to consider is ethical constraint. Knight Nite uses a microphone in order to monitor user breathing. This could be a potential issue for users because sounds such as talking or conversation could be picked up by the microphone accidentally if the device is still turned on. We will address this constraint by making sure that we used random access memory (RAM) to store the sound data. Random access memory stores data only when power is applied to the unit. The random access memory that is used for Knight Nite will be refreshed periodically so memory will constantly be erased and written over throughout the night.

8.1.3 Health and Safety

Since Knight Nite is a project and not a product it is not being sold and thus doesn't have any constraint or limitation as to selling it. If it were a product though the most important thing to emphasize is safety, possibly one of the major reasons there aren't many sleep treatment system is because the general public is scared that such a system won't be safe unless under medical supervision. The truth is that people are not getting the right amount of sleep either, they can take sleeping pills, or use other sleep devices. Since Knight Nite will monitor vitals, temperature, snoring and ambient light that provide treatments that will make sure the user will get an adequate amount of sleep. We plan to enhance the monetary constraint by picking the most well priced parts as well as building certain things that will cost more to buy. We also plan to make our system as secure as possible so that the user can feel safe sleeping with our system.

Using artificial light sources such as LEDs can have some health effects on the user that will affect how LEDs are incorporated into this project. Energy from the light is emitted and puts undesired stress on the eyes. For one thing, LED lights can potentially cause retinal damage of the eyes. LEDs, or screens that use artificial lighting, shine light directly into the eyes of the user. According to studies, eyes are made to see in the presence of surrounding light. Based on the amount of light in the environment, the pupil adjusts to provide the best vision for the person. Looking directly at a light source is not a natural situation that the eyes are made to deal with. As a result, the eyes will deteriorate after a long period of looking directly into artificial lighting. We address these safety concerns by first limiting the amount of time that the LEDs shine on the user's face.

Studies also show that LED light, specifically blue light, can reduce melatonin levels. Although a reduction in melatonin levels is good for waking up in the morning, other health concerns can arise from the reduced melatonin. A lack of melatonin can weaken the immune system and leave the human body more susceptible to infection. Since the LED light for this project are going to be shined on the user's eyes for a short amount time (around two minutes a day), the amount of melatonin reduction will be lowered. In addition, an opaque material will be placed between the user's eyes and the LEDs to lessen some of the glare and direct exposure.

8.1.4 Timing

A time constraint is a restriction to a certain project or product by the available period of time there is to complete it. The time constraint on Knight Nite is two semesters. The first semester, this semester, is focused on planning the project. This includes drawing schematics and preparing to build it. The second semester, next semester, is focused on actually building the project. This is also when we will test it and hopefully our plans and schematics are correct and the system will be fully functional. As is discussed in the milestones section below we split up the time we had into sections dedicated to research, planning, building a prototype, testing, and the final product. Also since we started the first semester in the spring (January through April) and the second semester is in the summer (May through August) that gives us 32 weeks total to complete both the planning phase and the building phase of Knight Nite. However, since it would be ideal to finish the project earlier so time can be spent writing papers and making presentations the time period is actually shorter than 32 weeks. In order to optimize the time we have we plan to implement the predetermined schedule perfectly and thus keeping on the correct timetable.

9. Hardware and Software Design

The hardware system components of Knight Nite are the set of subsystems, each encapsulating a particular function of the system, and the data processor unit that is a smartphone. Figure 22 is an overall system block diagram showing the relationships between subsystems and the data processor. The data processor, otherwise known as the visualization and control unit (VCU), is a smartphone hosting a graphical user interface application that reads sensor data from a USB interface, transforms data into engineering units, and provides supervisory control of each subsystem. Additionally, the application presents sensor data as readouts and graphs. Each subsystem contains a microcontroller hosting software to capture data from sensors, update a control algorithm, and send control signals to devices. Each microcontroller is responsible for interfacing to different peripherals to read sensor data and transmit normalized values via USB to the VCU.

The initial design of Knight Nite was to have everything controlled by a single main microcontroller. This microcontroller would take in all of the data in from the sensors and subsystems and based on one single control algorithm, tell the other systems what they should do. This is known as a monolithic approach. By having only 1 controller for all the subsystems, it may seem simple from a design perspective to control everything from one source. However, there is a large amount of room for error when doing this. By putting all of the control power into one PCB, it will be difficult to troubleshoot issues if problems were to arise with specific subsystems. A block diagram for the initial monolithic hardware system design is shown in Figure 21 below.

The modular approach allowed us to further explore different features we wanted in Knight Nite due to the fact that it was easy to see subsystems that branched out from the center. By having this diagram and image, more ideas came about regarding the vital signs, audio system, and light system. Furthermore, the design process for 1 MCU seemed simple and effective while also being cost efficient. Without having too many parts, the monolithic approach at first was the initial featured design choice. A block diagram of the final modular hardware system design is shown in Figure 22.

After researching many other similar existing projects and ideas, a modular approach was viewed as a more favorable design approach for Knight Nite. By having all of the sensors and subsystems have their own microcontroller and printed circuit board design, the system was much simpler.

Each microcontroller for each subsystem will relay information pertaining to their subsystem to a centralized data processor. This data processor will be controlled by the user and will have the ability to relay back control information to the individual microcontrollers with the exception of the vital system's microcontroller. Because the vital systems microcontroller is strictly a data information collector, there will be no data in control from the data processor to the vitals microcontroller.

The user will be able to control how often the cooling system will turn on and off or at what constant temperatures they want their forehead to be controlled at. Similarly, the user will be able to send control signals to the microphone microcontroller in order to determine whether or not they would like white noise as an optional treatment. The user can opt in or out of this specific Knight Nite feature. Therefore, the system offers flexibility for the user. The light system microcontroller will also be able to receive control signals from the data processor in order to program certain wake up times. Furthermore, the Knight Nite emergency system will send control signals to all subsystems in the event that the user needs to be woken up due to a heart attack or lack of healthy vital signs. Table 23 describes the hardware components of each subsystem.

Table 23 Knight Nite Subsystem Components

Subsystem	Vitals	Audio	Light	Cooling
MCU	STM32	STM32	STM32	STM32
Sensors	Heart Rate, Forehead Temperature, Motion	Microphone, Speaker System (Buzzer)	LED, Photo-transistors	N/A
Mechanical Components	N/A	N/A	N/A	Pump, Vinyl Lines
Estimate Power Consumption	11mAh	11mAh	11mAh	11mAh

Although this may not be the most cost efficient method, the separate systems allow for easier troubleshooting and design schematics. For example, if there was a problem with the light system not working, the procedure to troubleshoot the problem is to first directly go to the light system. If this were a monolithic approach, it would be very time consuming in order to troubleshoot the lighting system microcontroller and program. Having a monolithic system also poses the risk of damaging the other systems during troubleshoot. Therefore, each subsystem in the second modular design will have its own microcontroller and programming in order to simplify the design entirely.

9.1 Emergency System

In the event of an emergency where the user needs to wake up, a control algorithm based on the block diagram below will be implemented. If the heart rate sensor shows zero readings, the vital systems microcontroller will immediately send signals to the data processor in order to notify all of the other subsystems to wake up the user as soon as possible. The low level block diagram is shown in Figure 23.

Based on this block diagram, the cooling system will immediately take action by trying to lower the forehead temperature significantly. Based on studies by the Vanderbilt Heart And Vascular Institute, lowering the body temperature to 86 degrees can significantly decrease the risk of brain damage for a patient in the event of a heart attack. Therefore, Knight Nite will be able to at least lower the forehead portion of the user if the user were to have a heart attack.

Meanwhile, the audio microcontroller will start playing loud audio mp3 files in order to alert someone in the near area that the user is in trouble and needs medical attention immediately. The audio files can either be a verbal cry for help or a basic alarm. This can also be determined in the user interface. Although the user will not ever want or plan to have a heart attack, Knight Nite provides them a peace of mind while sleeping to ensure that they will receive help if needed.

The light system microcontroller will be sending signals to all LEDs to turn on at maximum intensity to help wake up the user. This process can be programmed in multiple ways depending on further testing. For example, the LEDs can be turned on at maximum intensity and stay on for a long period of time. However, they can also be programmed to flash intermittently to try to get the user's attention more effectively.

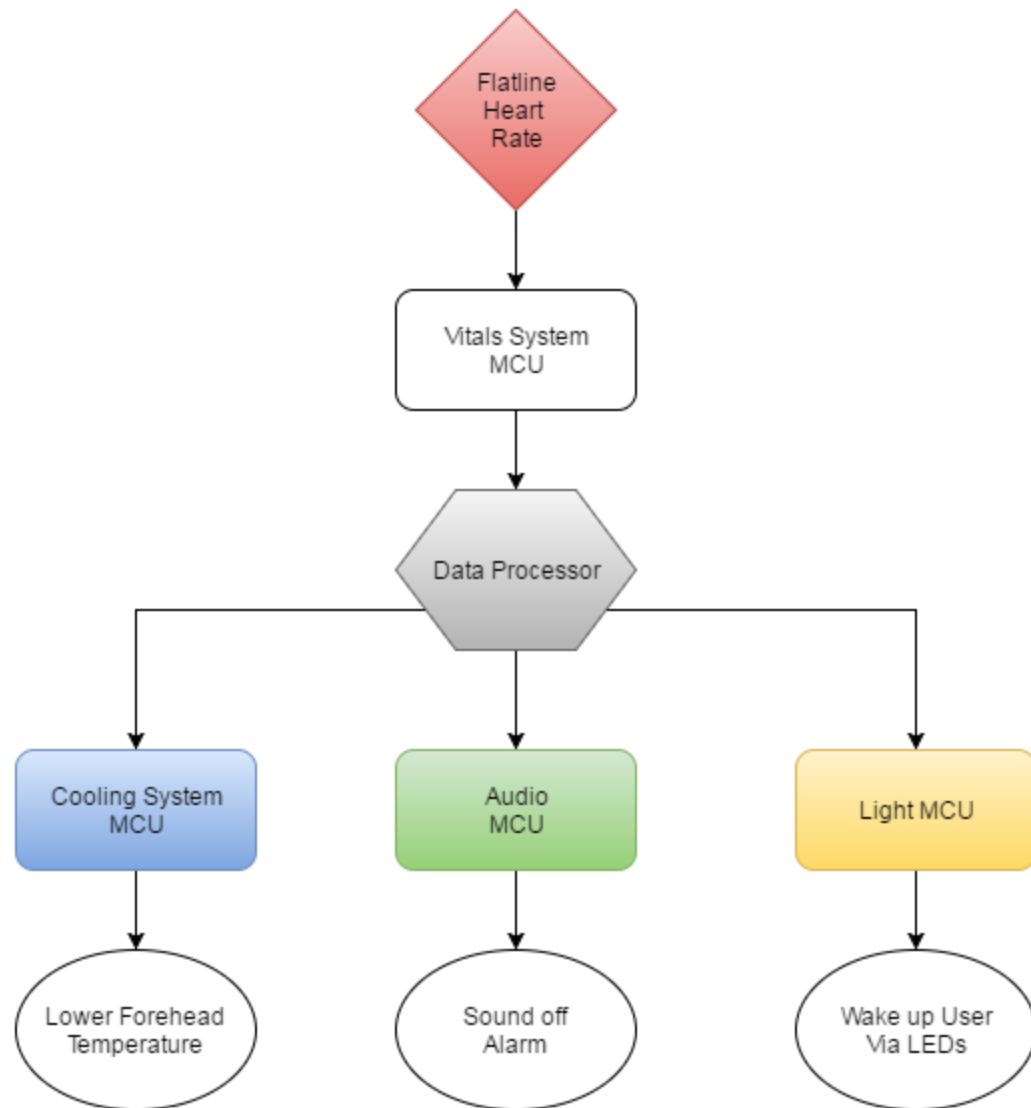

Figure 23 Emergency System Block Diagram

9.2 Vital Systems

The entire vital system consists of multiple subsystems that contain its own data processor. By separating each subsystem into its own category, it simplifies the entire vital section of the project and make it easier to implement, troubleshoot, and test. For example, during testing if the heart rate monitor were to fail to give a reading, we know exactly where to go in terms of troubleshooting the system. The only source that could cause the problem is the subsystem of the heart rate monitor.

Although each subsystem will contain its own microcontroller unit, they will be relatively the same in design to keep consistency and simplicity with implementing the systems and with programming. Below are simple block

diagrams of each sensor for the vitals systems unit that shows how the data will ultimately be presented and collected from the user. Most data collection from the sensors, such as the temperature sensor, will be collected via an analog signal. Therefore there will need to be some analog to digital conversion in order to get a digital output for the main MCU to utilize. After the main MCU receives the data, a full feedback design will be implemented so that other units in the system know what to do (i.e. cooling system or light system) based on the information given through feedback.

Furthermore, the vital system will implement what is known as a fail-safe feature. This feature will wake up the user in case of user-based complications such as a heart attack or stroke during sleep. Although uncommon, if a user starts to experience heart, breathing, or any other life threatening problems, Knight Nite will do it's best to wake up the user immediately or call for help. For example, the lighting system will do its best to provide ample amount of light over and over again so that the user will regain conscious. The audio system will be programmed to play certain audio files that will aid the user into waking up such as an alarm. The temperature sensor block diagram is shown in Figure 24.

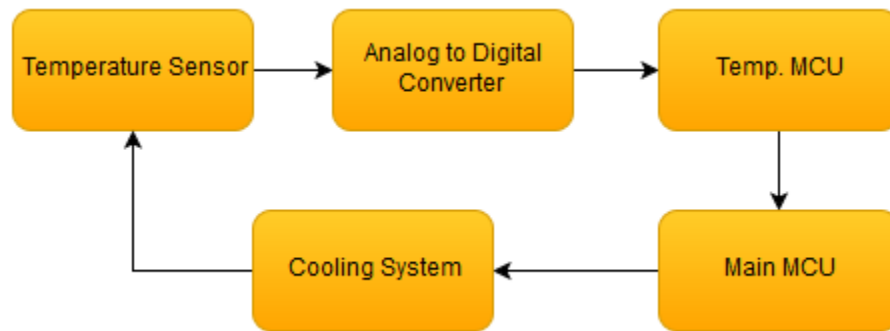

Figure 24Temperature Sensor Block Diagram

This is a basic block diagram of the temperature sensor that will be used in vitals monitoring system. By measuring temperature, Knight Nite will be able to use this data in correlation with other diagnostics of the user to see what is wrong with the user during sleep at certain times of the night. For example, if the user is experiencing night sweats at a particular time of the night, he or she can refer back to the data interface to see what temperature their body was during the episode.

The temperature sensor system is a closed loop feedback system that gives information to the cooling system and data processing center. The sensor picks up an analog signal which then is converted into a digital output using an analog to digital converter. From there, the temperature MCU will output the data via digital signal to the main MCU for data processing.

After the data from the temperature sensor is received in the main MCU, the cooling system will react based on the information given by the temperature sensor. However the cooling system is not getting direct readings from the main MCU. It is getting its temperature readings directly from the temperature sensor in order to determine whether or not to turn on the cooling system. For more information on how the cooling system works, refer to the cooling system design section. Figure 25 Shows the MLX90614 as well as Figure 26 shows the motion sensor block diagram.

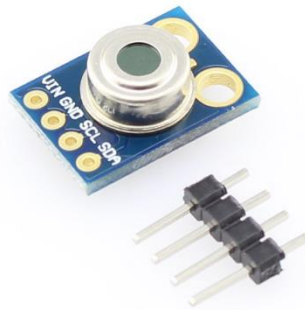

Figure 25 MLX90614

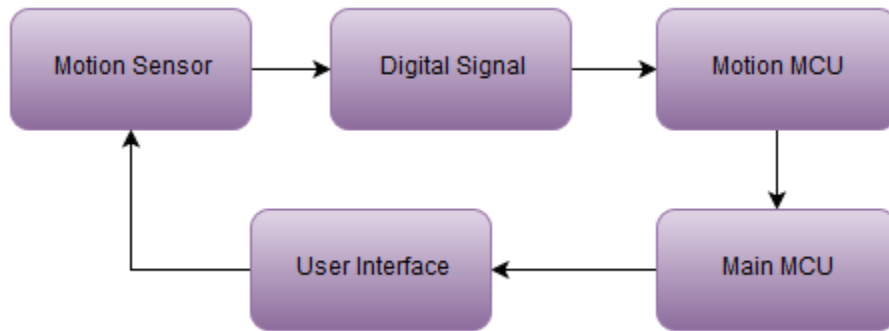

Figure 26 Motion Sensor Block Diagram

The motion sensor unit is similar to the temperature subsystem however it is actually much simpler. This is because the motion sensor unit is not affecting any other subsystem in any control algorithm (excluding emergency wake-up). Therefore, the purpose of the motion sensor is just for data processing to show the user the behavior of their sleep patterns during specific times of the night.

The motion sensor picks up a signal from the user, high or low, depending on the user's state. A high signal would mean that the user is moving and a low signal would mean the user is not moving. Then, the data is sent to the motion MCU

which is then sent to the main MCU for data processing and user interface as shown in Figure 27.

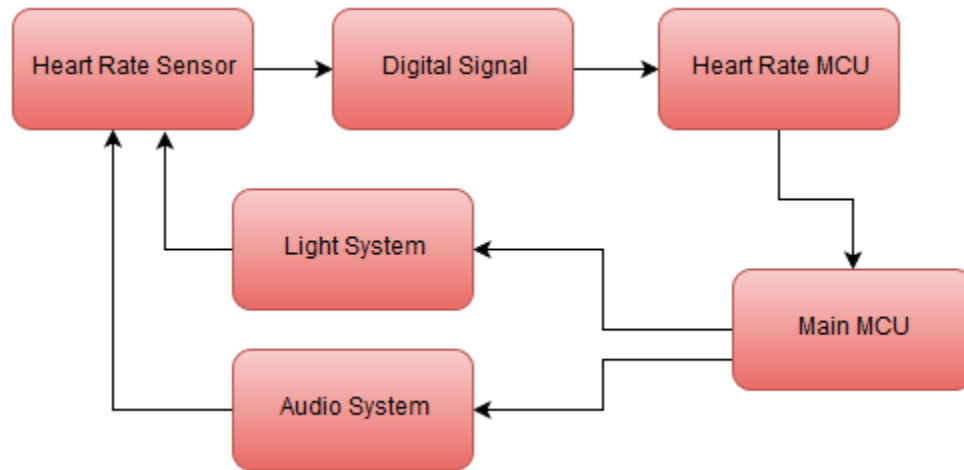

Figure 27 Vital System Block Diagram

The heart rate sensor affects two other subsystems in Knight Nite. The two subsystems that it affects are the light system and the audio system. This feature of Knight Nite is the fail-safe user wake-up system that will be implemented in case the user experiences sudden life threatening situations. Through a simple control system, if a user's heart rate is well beyond or below the limitations (programmed in the main MCU), all the other subsystems will attempt to wake up the user as soon as possible through various sound and light techniques.

The heart rate sensor will output a digital signal using the heart rate MCU which will transfer the data from the main MCU. From there, the main MCU will send signals and instructions to the light and audio system in an event where the user needs to be woken up. Therefore, there will be a closed feedback system that incorporate the heart rate monitor and the other subsystems to immediately wake up the user in case of an emergency.

9.3 Audio System

The audio system unit is an independent implemented subsystem of Knight Nite. It converts analog signals to digital using the analog to digital converter (ADC) on local MCU before sending the data to the Knight Nite's main MCU for data processing. An ADC is an electronic device that converts a continuous physical electrical quantity to a digital value. The physical quantity is generally voltage however it can also be current. An analog signal is sampled at a specified "sampling rate" to get the digital value of the amplitude of the signal. The higher the sampling rate is, the more data points we have per second and thus the more accurate representation we have of the analog signal. However one issue engineers run into is that the higher the sampling rate, the more space it takes to store the data. One way to get a good balance between storage and quality is the

Nyquist Theorem. The Nyquist theorem states the sampling rate on an ADC must be at least two times the highest frequency you want to capture. For example, if we were recording music, the highest frequency humans can hear is 20 kHz so if we wanted to record music with good storage to quality balance we would need at least at least 40 kHz sampling rate.[31] The resolution of an ADC is another important consideration. Most embedded microcontrollers have either a 10 or 12 bit resolution on their ADC's.

Let's consider a 10 bit ADC, that means it can capture up to 2^{10} (which is 1024) discrete digital values. In reality the value of the reading would be between 0 and 1023 which corresponds to the amplitude of the input analog signal. The higher the resolution, the more accurate your ADC will be as well. If we had a microcontroller with a maximum analog input of 3V (which is typical) we can see the effect of resolution on our accuracy with some math. As we can see, there is a significant accuracy difference that comes with just two more bits of resolution. [32] The microphone system is shown in the low level block diagram in Figure 28.

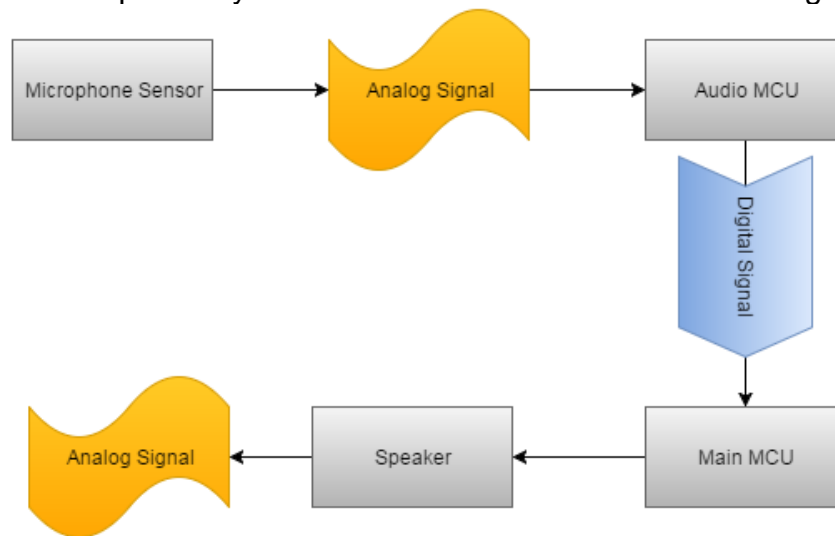

Figure 28 Audio Block Diagram

9.3.1 Microphone

The AOM-4544P-2-R will be the microphone used to detect snoring. It was an overall better microphone in terms of sensitivity, low voltage requirements, wider frequency response, and low price. The circuit in Figure 29 uses a low-pass filter along with an instrumentation amplifier. The third order low-pass filter that was designed allows the magnitude to reach zero exactly one decade after the cutoff frequency. In researching the design a filter is needed to detect breathing and reduce the influence of external noise. The low-pass filter will limit the frequencies to a range of 0 Hz – 300 Hz; this is because the highest peaks of intensity regarding snoring occur in that frequency range. The signal from the microphone will need to be amplified to be read by the microcontroller so the instrumentation amplifier has a high gain to increase the signal. The Bode plot in Figure 30 shows

that the low-pass filter for this design has a cutoff frequency of 300 Hz. The phase response is shown in Figure 31.

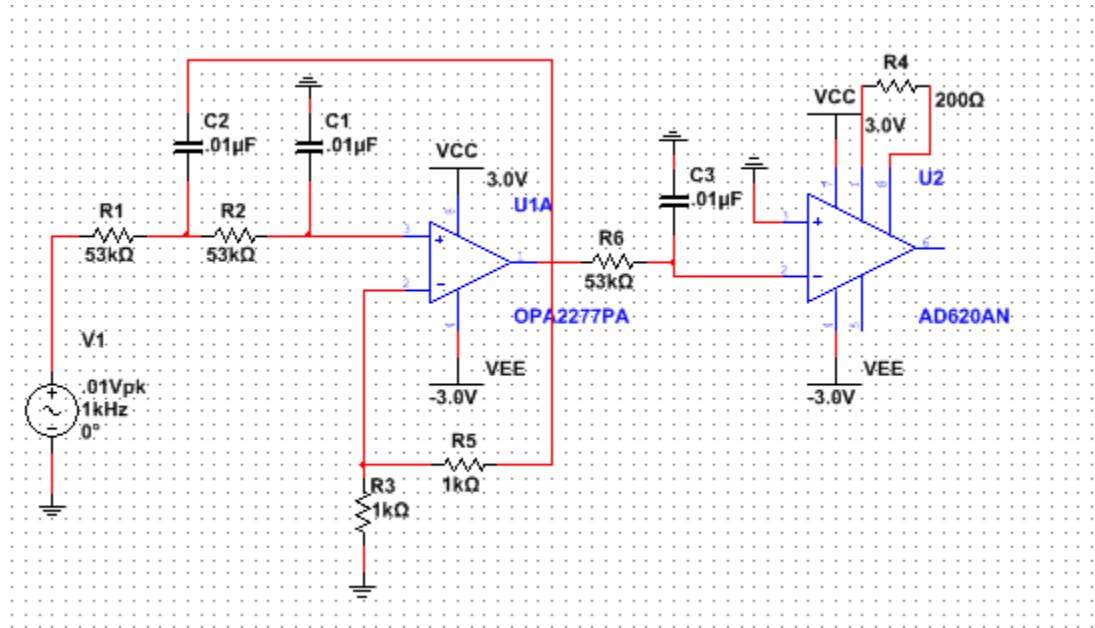

Figure 29Microphone Schematic

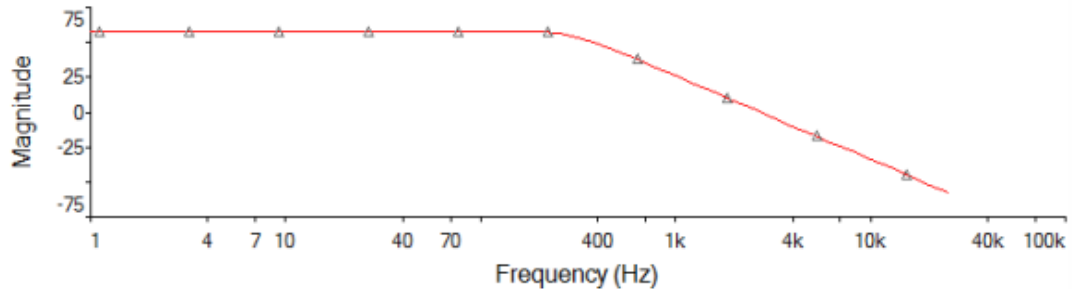

Figure 30Magnitude Plot

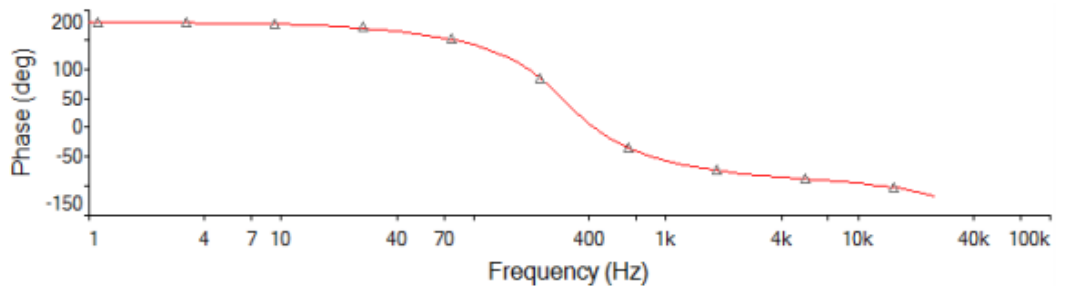

Figure 31 Phase Plot

There are a few other potential strategies for detecting the snoring with the microcontroller. Instead of constantly using the ADC over a certain interval of

time, some resources might be saved using the peak detector circuit. The idea is that the microcontroller reads from the peak detector output only once in the equivalent time interval instead of continuously reading. The peak level read will be a representation of the highest level of snoring during that time interval. The microcontroller will then apply voltage to the gate of the MOSFET to drain the capacitor so that new snoring peaks may accumulate. This may not be as accurate as averaging many values, so both methods will be tested. Figure 32 is a peak detector circuit design that would be used to indicate the highest degree of snoring during a certain time interval

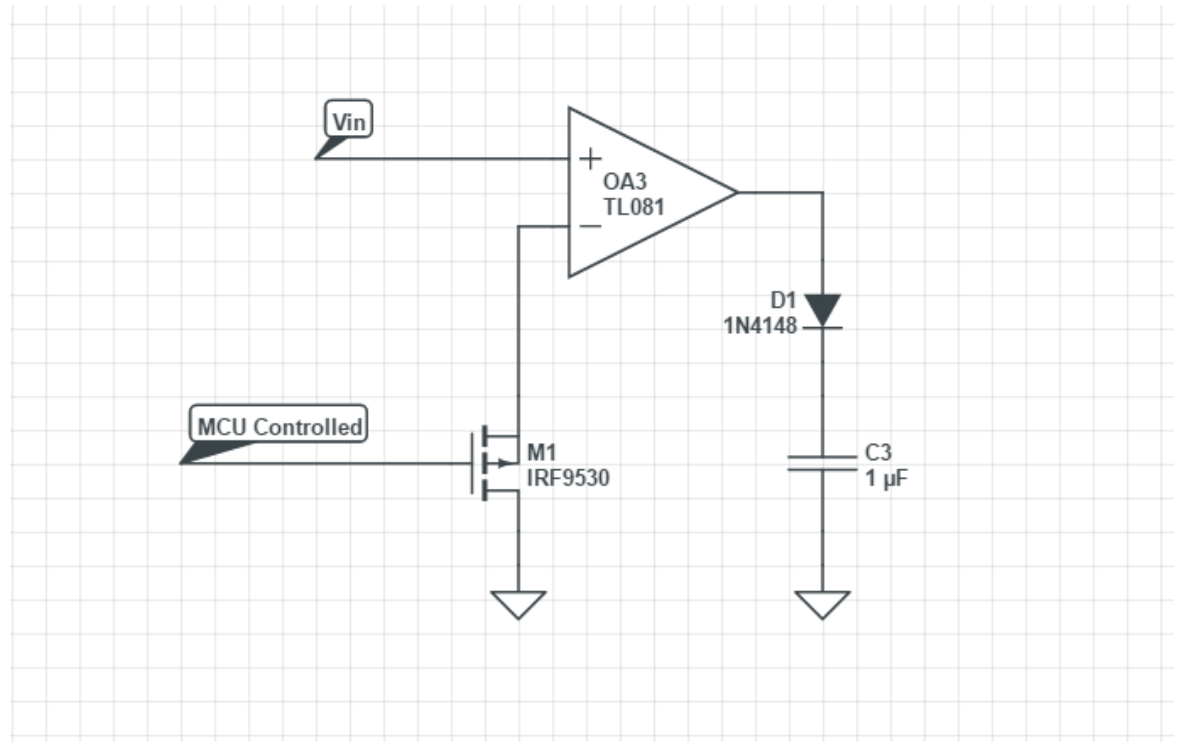

Figure 32 Peak detector circuit design

9.3.2 Buzzer

The system will make use of a buzzer to act as an audible alarm. This buzzer will need to produce a tone that is capable of waking someone in any stage of sleep or helping them go to sleep. Most of the buzzers available are capable of producing a wide range of frequencies. Electromagnetic type and the piezoelectric type are the two main buzzer categories. Before we selected the buzzer for this project, it is necessary to determine which type will work best for this design first.

Both types of buzzers work by using electronic components to convert an input voltage into an appropriate oscillating signal which drives a metal sounder diaphragm. The electromechanical buzzer is able to obtain low frequencies,

because they are typically small in size. If size was a factor, it would definitely be the best choice of the two. However, this type of buzzer has many drawbacks associated with it such as mechanical wear, electrical noise, lower sound output, and large power consumption. Not to mention, it is also important to consider the operating life of the buzzer due to the mechanical operating characteristics of this type of buzzer.

The electromechanical alarm has an electrical contact inside that keeps opening and closing that typically has a high failure rate. The piezoelectric buzzer is better in many ways than the electromechanical type, because it does not have any mechanical devices that move. Meaning it has a greater operating life than the electromechanical buzzer since there is no mechanical wear on the device. The piezoelectric buzzer is capable of operating in a much wider variety of environments. This type of buzzer draws very little current making it suitable for a battery or in this our case USB powered application.

Of these two types of buzzers only the piezoelectric buzzer type will be considered when selecting parts. This is because of the electrical noise and the high power consumption of the electromechanical type. Since an electromechanical design can draw up to ten times the current of the piezoelectric variety. The electrical noise will definitely make designing the alarm much more challenging since it will require greater attention to detail when considering how each part is impacted by the noise introduced. Since alarms that use piezoelectric technology draw less current, are capable of louder sound levels, and do not generate magnetic fields. When creating the alarm sound it will use pulsing tones. A pulsing tone can be more easily distinguished compared to constant tones.

When people hear a pulsing tone it will typically convey more sense of urgency to a person compared to a constant tone. In order to create a pulsing audible alarm we will need to create extra electronic circuitry and software code. To be an effective audible alarm it should be at least five decibels louder than the ambient background noise. This is so it can be easily heard. Most people can only distinguish a sound level change only when it increases or decreases by 3 decibels. When the sound level changes by five or ten decibels, the person who is listening would say that it is twice as loud as before. When generating the sound that will be the alarm it will be necessary to take into account how the human ear works to generate an alarm to wake the user.

The MCKP1206R1-4720 is a small piezoelectric buzzer that packs quite a punch. The buzzer supports a wide range of frequencies that will allow for a variety of tones to be produced as shown in Table 24.

The ABI-001-RC provides a little more detail in the specification sheet regarding operating current and voltage. This buzzer has a built-in oscillating circuit, which

will save time in the development phase. The specification sheet indicates that it has low power consumption as shown in Table 25.

Table 24MCKP1206R1- 4720 Product Information

Impedance	32 ohm
Sensitivity	115 dB
Frequency response	300 Hz –3.4 kHz
External diameter	6 mm
External height	12 mm

Table 25ABI-001-RC Product Information

Rated voltage	12 VDC
Operating voltage	3 – 16 VDC
Rated current	7 mA
Sound output	80 dB
Resonant frequency	4000 ± 500 Hz
Operating temperature	-20°C to +70°C
Weight	1 gram

The MCKPI-G4510L-4013 also provides more detail than the first buzzer listed. This buzzer has similar specifications to the ABI-001-RC except that this buzzer produces continuous tones. It may be beneficial to have a continuous tone and create a tune using a microcontroller, which is why this buzzer was also considered. Table 26 shows the product information.

Table 26MCKPI-G4510L-4013 Product Information

Rated voltage	12 VDC
Operating voltage	3 – 16 VDC
Max Rated current	35 milliamps

Sound output	100 dB
Resonant frequency	3200 ± 500 Hz
Tone Nature	Continuous
Operating temperature	-20°C to +60°C
Weight	21 grams

9.4 Lighting System

The light detection portion of this project is designed to collect ambient light from the environment and convert the light into a voltage as shown in Figure 33. Phototransistors will be used in order to get a converted voltage. The light detection circuit will consist of four phototransistors to get a more accurate and consistent reading of the voltage for different levels of light.



Figure 33 Detector Low Level Block Diagram

In addition, each phototransistor will be connected to an analog-to-digital converter to sample the voltage and convert it into a digital signal. Once we have the light voltage in digital format, converted light data will go to a separate MCU located on the circuit board used for the LEDs. Here, the data will be temporarily stored for a couple of clock cycles until we are ready to process the data. The next step is for the MCU on the LED circuit board to transmit the light data to the main MCU for data processing and data visualization.

9.4.1 LEDs

In general, the lighting system is designed to act as an alarm and wake the user up at designated time of the day. To generate the light necessary to wake the user up, LEDs will be used because they are small in size and are cheap compared to other light sources as shown in Figure 34. The LEDs will be arranged into two sets, and each set will consist of three parallel branches of LEDs. A sleep mask made of synthetic leather will be used to house the LEDs.

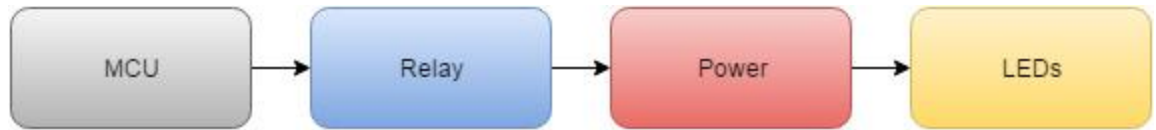

Figure 34 Light System

The mask will be worn by the user while they are asleep. The inside of the mask will have the printed circuit board and a mesh material will go over the LEDs so that they do not rest directly on the eyes of the user. When the MCU on the printed circuit board sends a control signal to turn on the LEDs, the signal will go through a solid state relay in order to switch power to the relay. The solid state relay that will be used for this project is the VR1142A6. For power, coin cell batteries will be used since they have a flat structure.

9.5 Cooling System

The cooling system takes in information from the temperature sensor in order to determine whether or not it will be used. Based on scientific sleep studies, the act of bringing the temperature of a user’s forehead down will help them fall asleep faster. The cooling system will receive the temperature data from the sensor and will be told whether or not to turn on from the main MCU. At this point, the pump takes water from the water reservoir (already pre-cooled) and proceed to flow water through the tubes to the forehead where it will cool the user via a cooling contact patch. A simple block diagram of the cooling system is shown inFigure 35.

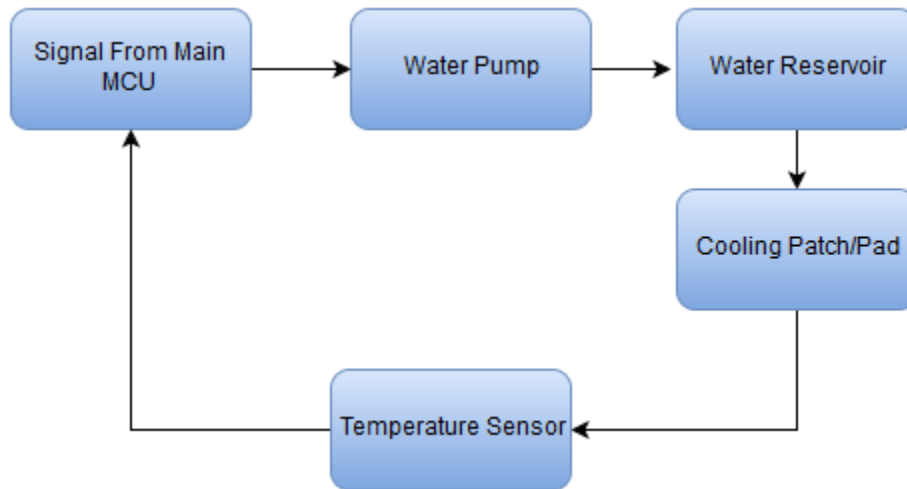

Figure 35 Cooling System Block Diagram

The materials used for the cooling system will be simple yet efficient. The lines used to transfer the water from the reservoir to the patch and back will be ¼ inch rubber tubing that can be purchased at any hardware store. The reservoir will

consist of small tank roughly 3 liters in size. Since the water needs to be cold enough to cool down the user.

9.5.1 Pump

The pump used in KnightNite will be the Docooler mini pump. This is the most cost efficient and practical pump for this project due to its moderate flow rate and low cost. It features a 240L/hour flow rate which is an ample enough rate for this project. The pump is also waterproof which allows for it to be submerged in the water reservoir which results in a simpler design.

The reservoir that will be used will be at minimum 4 liters in volume. Since the Docooler pump used pushes out water at 240L/hour, it will cycle through 4 liters which will be plenty of water for the entire cooling system to run. The cooling system will be tested at first with just a bucket of water. Further implementation and design of the reservoir will have an enclosed case for the water so that it does not have the possibility of spilling over.

9.5.2 Fluid

The two types of fluid that were considered for Knight Nite was water and coolant. Since water is corrosive, it created potential problems in the design aspect where it may damage the hardware further down the road. Although water is corrosive, it is also non-toxic which is a good factor because if there are complications in the hardware being broken, the user does not have to worry about the liquid being harmful.

Coolant was considered as one of the liquids to be used because it is non corrosive. However, coolant is toxic which makes it less desirable even though it would not be able to damage the hardware materials in event of a corrosive environment. Therefore, water will be used as the liquid for the cooling system.

9.5.3 Fluid Lines

The fluid line that will be implemented Knight Nite is a 7/16 x 5/16 vinyl fluid line made by Watts. This line is waterproof and provides a tight seal with the Docooler water pump. Furthermore, this line is flexible enough to work with so that it is able to bend and move around the head unit. Also, at 4 dollars per 10 foot of line this product is cheap which makes the cooling unit more cost efficient. Further testing of this vinyl line will be done during construction to see if the lines can withstand multiple sleep cycles.

9.5.4 Power

The overall power design process will follow the most used topologies in the market for the alternating current supply and the direct current supply. The fly back topology is popular in AC to DC due to its isolated design. For the DC power supply source, a buck converter will be implemented in order to control the voltage signal to a desired specification.

9.5.4.1 AC Power Design

Figure 36 shows the UCC28700 controller working to implement an isolated flyback topology design. This alternating current to direct current converter was the optimal choice in the design process. Although the UCC28700 is not the most efficient controller, it offers the best balance between efficiency and the footprint size which must be taken into consideration when building the power supply.

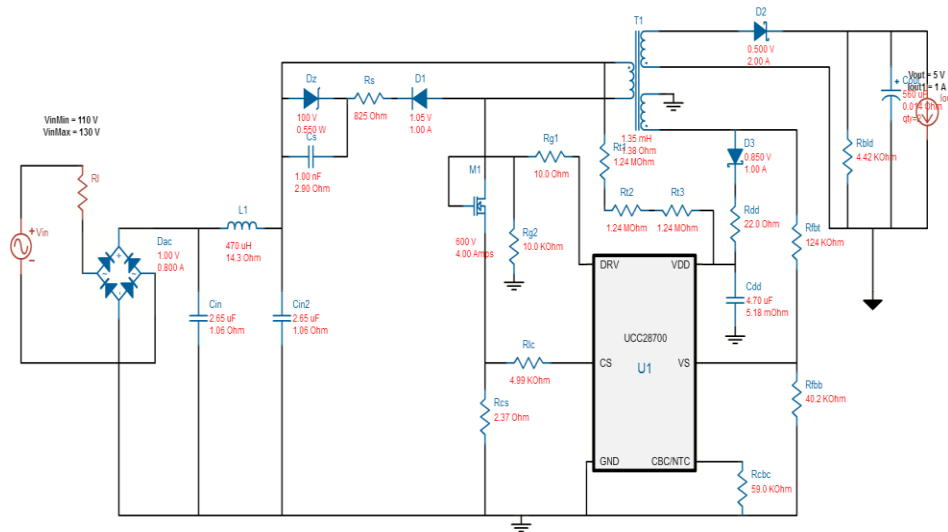

Figure 36 AC Power Isolated Flyback Topology with UCC28700 Controller

The footprint will affect the build of materials list which affect the cost and the efficiency will affect the performance. Furthermore, the UCC28700 provides a constant voltage and current output using the built in regulator without the use of an optical coupler. Furthermore, the controller uses low current to turn on and is dynamically controlled through operating states. The error percentage for the regulation is only $\pm 5\%$ while running on less than 30-mW.

Figure 37 shows the comparison of the power supply microcontrollers based on footprints and efficiencies. As seen in the graph, the UCC28700 is on the part of the graph with the highest efficiency and lowest footprint. It was also compared to the UCC38C42.

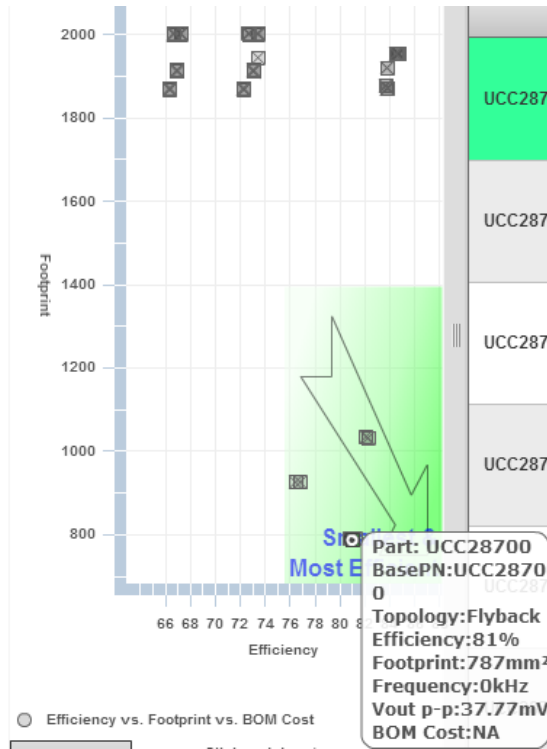

Figure 37 Power Supply Comparisons

Although the UCC38C42 had a higher efficiency, it lacked in the footprint size area being one of the larger sized footprint microcontrollers at around 1900mm². Furthermore the UCC28910 high voltage fly back switcher was also considered in the design process for the power supply. The low number of parts for the footprint and the low operating frequency made it ideal for the power supply system. However, the footprint size and efficiency still fell behind the UCC28700 which was the deciding factor in picking which controller would be best to implement this fly back topology. Figure 38 shows the overall average power design requirements and values for the fly back controller system.

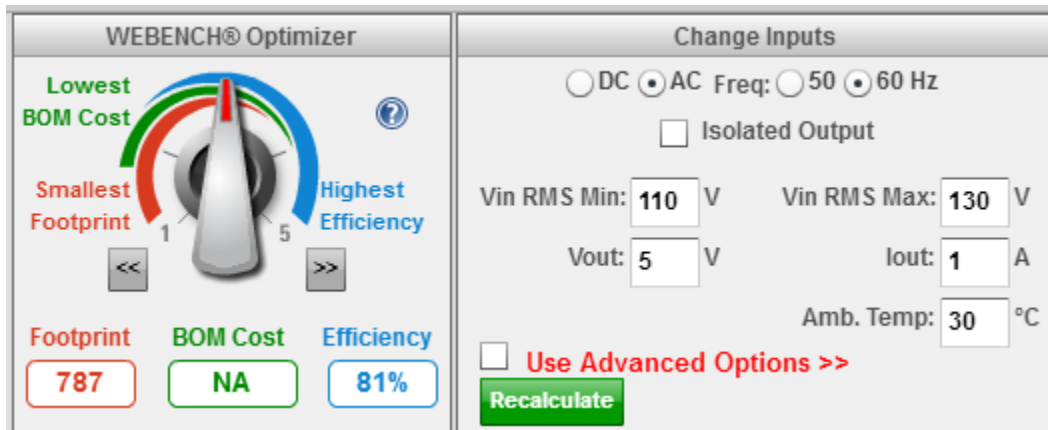

Figure 38 Average Power Design

When picking the proper power supply controller for the custom made printed circuit board, there were several factors that needed to be taken into consideration. The Webench optimizer helped with the design process by giving a list of the best controllers for the parameters inputted into the program. The current desired coming out of the power supply system was 1 amp which was an ample amount to work with. Furthermore, the voltage input and output root mean squared values were coming from a standard American wall outlet so the parameters from the voltage were given between 110 volts and 130 volts. The typical ambient temperature for the system was given at around 30 degrees. These were the following input values for the Webench optimizer for the AC to DC power supply as shown in Table 27.

Table 27 UCC28700 Specifications

Controller	UCC28700
Type:	Flyback
Output	DC
Vin minimum	110V
Vin maximum	130V
Source	AC
Desired Voltage Out	5V
Current Out	1.0 A
Operating Temperature	30 degree C

Figure 39 shows the efficiency output based on the current the power supply printed circuit board will be providing. The 3 signals seen in the graph show the varying alternating current voltage inputs from 110 to 130 volts. The efficiency of the fly back system peaks at around 0.5 amps which is the ideal for the requirements of the power supply system.

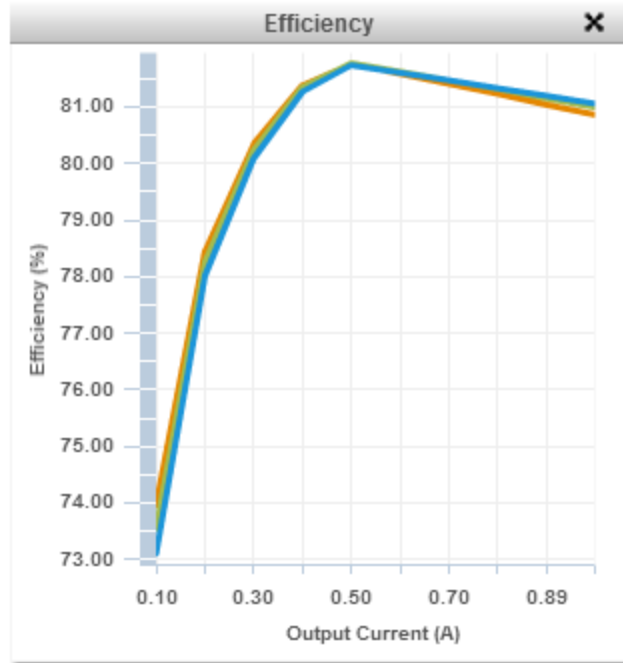

Figure 39 Efficiency

Figure 40 shows the comparison in the duty cycle of the 3 different signals of the UCC28700 flyback controller. The duty cycle shows the percentage of time the signal is active during one period of the signal. The duty cycle peaks at highest output current. As the power supply system outputs a higher current, the duty cycle increases.

■ Vin=110.0V
 ■ Vin=120.0V
 ■ Vin=130.0V

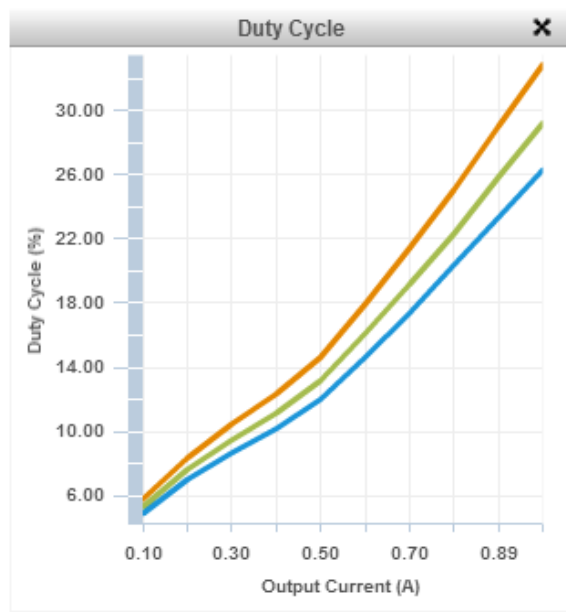

Figure 40 Duty Cycle

Figure 41 shows the power dissipation during standby mode of the microcontroller. This feature is important in the design process of the UCC28700 because it should meet the efficiency requirements of the design and not waste power even when it is not running. As the voltage input increases the amount of power dissipated increases which is expected for a flyback topology.

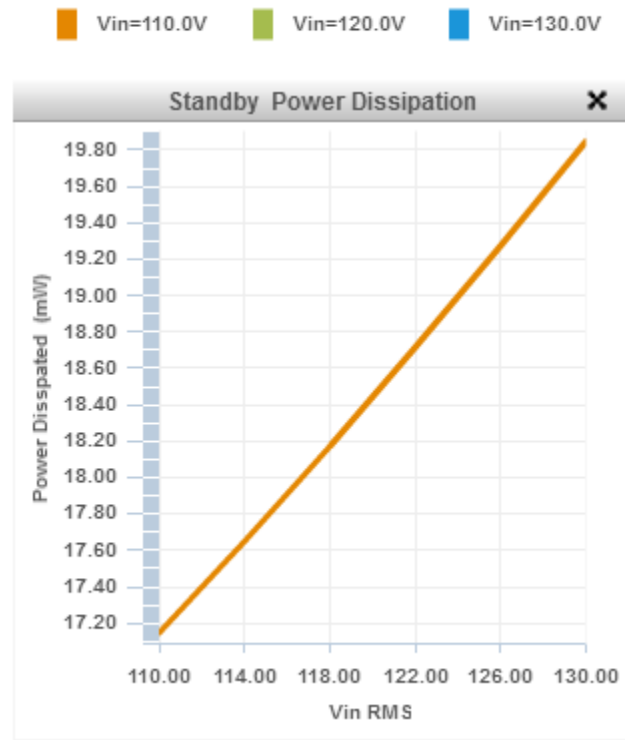

Figure 41 Power dissipation

9.5.4.2 DC Power Design

The buck converter design schematic is much simpler than the flyback topology as seen in Figure 42. The TPS52336A buck converter features MOSFETs that work in parallel to provide a 3 ampere output current. Furthermore, the low operating current controller uses an enable pin to reduce the shutdown supply current to only 2 micro amperes.

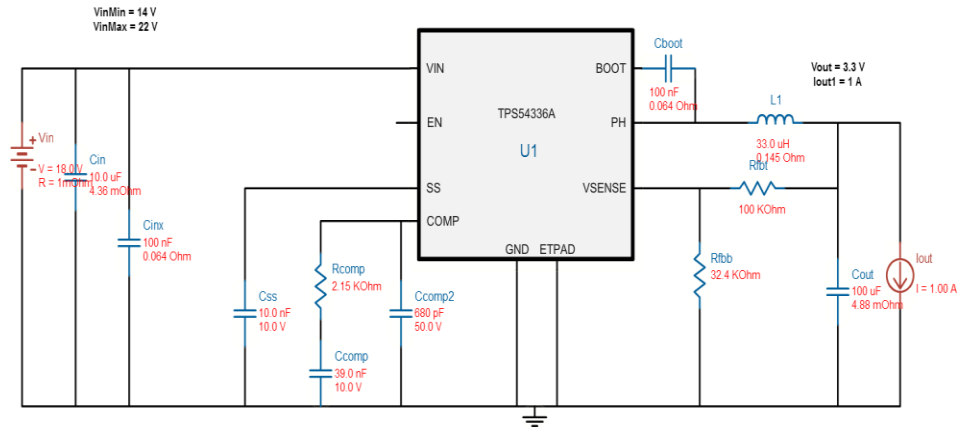

Figure 42 DC Power Buck DC Topology with TPS54336A Buck Converter

The converter also features a pulse skipping characteristic that provides light-load efficiency. Furthermore, this synchronous converter offers damage protection through its thermal shutdown technology and overvoltage transition protection. As seen in **Figure 43**, the TPS54336A falls under the category of the smallest footprint and highest efficiency values. Compared to other power converters, this specific converter also features the most cost efficient system when implementing all of the passive and active parts together.

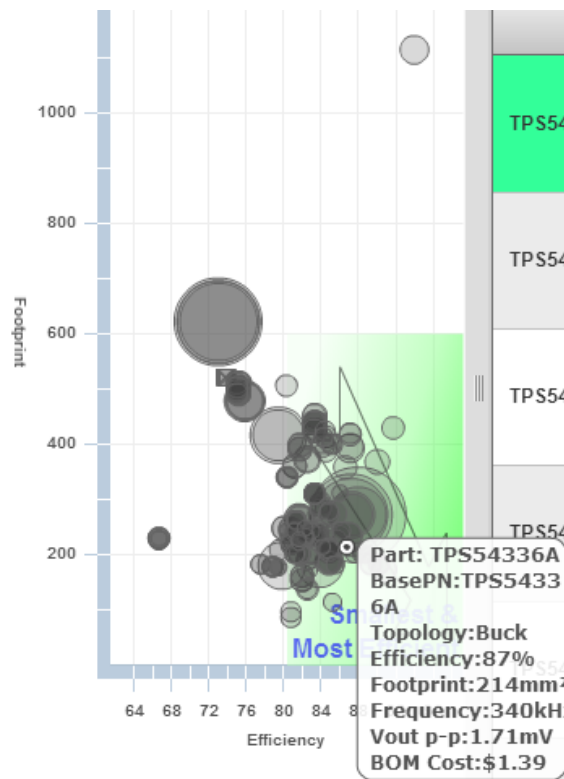

Figure 43 Topology Comparison

Using the Webench optimizer, the average efficiency rating for this DC power system comes in at 87%. Therefore, it is safe to realize that any buck converter design chosen for this system must be within the 87% efficiency mark. Furthermore, the parts for this printed circuit board is estimated to be around \$1.39 which makes this system cost efficient. Figure 44 shows the estimated footprint, build of materials cost and efficiency percentages for the possible buck converter configurations based on the inputs given.

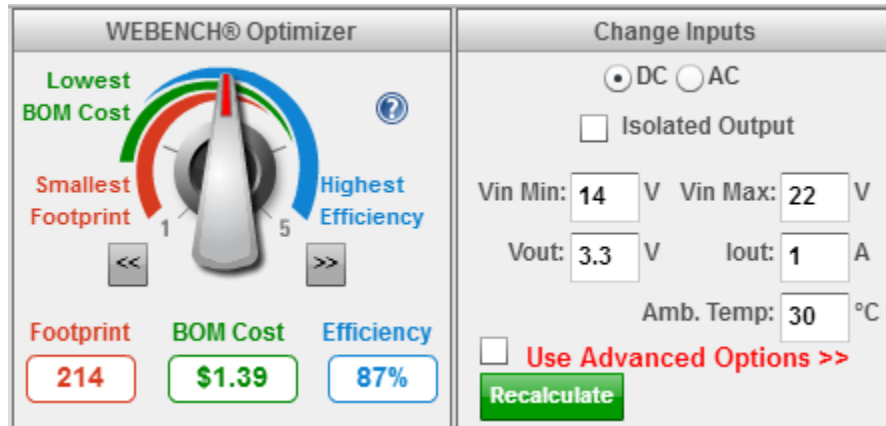

Figure 44 Optimizer

The TPS54336A was the desired integrated switch to use for the DC to DC power supply system due to its low power usage and desired current output. The system was designed to run between 14-22V with a 5V output at a current of 1.0 ampere as seen in **Table 28**. Furthermore, the technology on the TPS54336A features built in control algorithms that make the settling time of the integrated switch much quicker than a traditional buck converter.

Table 28 TPS54336A Specifications

Controller	TPS54336A
Type:	Buck/Integrated Switch
Output	DC
Vin minimum	14
Vin maximum	22V
Source	DC
Desired Voltage Out	5V
Current Out	1.0 A

Operating Temperature	30 deg C
-----------------------	----------

Figure 45 displays the efficiency of the TSP54336A buck integrated switch between the output voltages varying from 14 to 22 volts. As expected, the lower input voltage yields higher efficiency while the higher input voltages yield a lower efficiency percentage. An interesting feature to note about this integrated switch is that the efficiency of this power system will peak at around 0.3 amperes. This is acceptable for Knight Nite because the usable current for the major subsystems will only be around 0.25 amperes maximum.

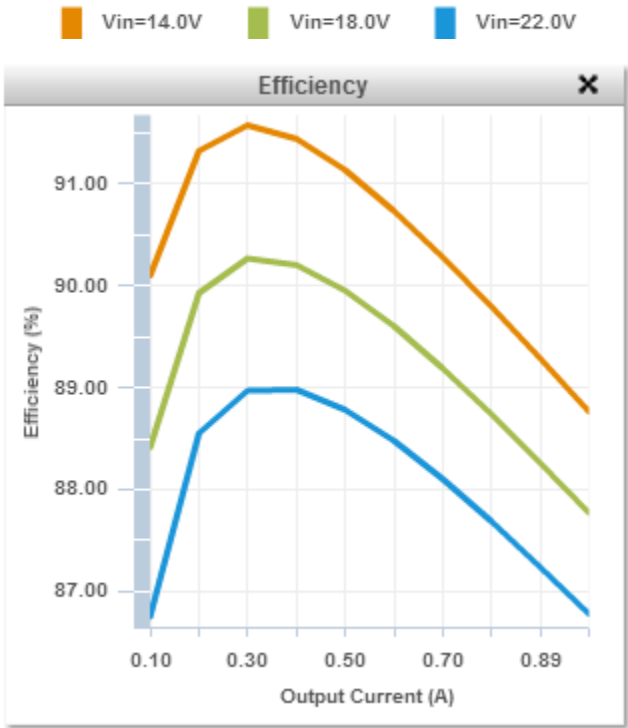

Figure 45 Efficiency

When designing the DC power supply, the duty cycle needs to be taken into consideration. With a lower input voltage, Figure 46 shows that the duty cycle percentage increases while the output current increases. Therefore, there may be some design requirements in the future which make necessary for certain subsystems to stay at various voltages and current outputs.

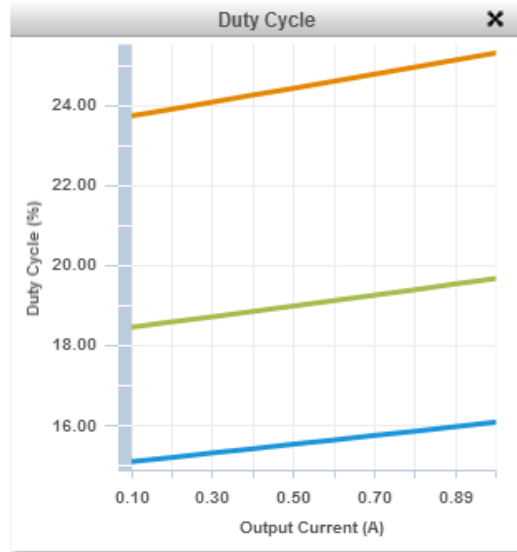

Figure 46 Duty Cycle

9.6 Software Design

The Knight Nite software design is logically partitioned based on the separate responsibilities of the visualization and control unit (VCU) and distinct subsystems. The responsibilities of the VCU are primarily data processing, supervisory control, and graphical user interface presentation. The responsibilities of each subsystem in general are sensor data acquisition and automatic process control. Each subsystem communicates bidirectional with the VCU over a Universal Serial Bus. The subsystems communicate normalized sensor data, receive commands, and send device status to the VCU. **Figure 47** is a block diagram describing the logical organization or architecture of the software. The approach taken in the Knight Nite software is a layered architecture for simplicity. The analysis and design of the software is done using an object oriented approach. However, the implementation of the VCU application and subsystem programs will take a structured programming approach.

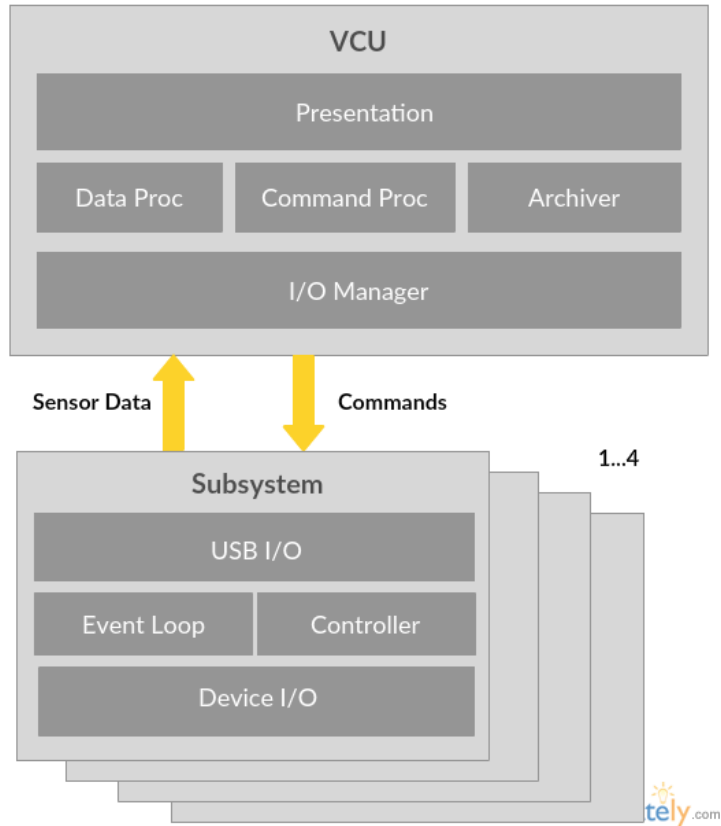

Figure 47 - Software block diagram

Each subsystem will share a common software design considering each has very similar responsibilities. Specific points of implementation differences in each subsystem are the particular device protocols and whether or not the subsystem is expected to do automatic control. For example, the vitals subsystem has no automatic control requirement. The device I/O software component will transform specific communication formats, for example Serial Peripheral Interface, to a normalized sensor data format. The sensor data format is additionally encapsulated in a packet structure for communication between the subsystem and VCU. The sensor data format is a structured data type shared between software on each subsystem and the VCU application. The C programming language is deliberately selected to program the subsystem MCUs and provide portable data structures to the higher level Java programming language used by the VCU application.

The VCU application processes sensor data, archives data, provides supervisory control of subsystems, and presents a graphical user interface. The application software is separated logically by concerns. The data processing class is responsible for transforming sensor data to engineering units and distributing data to the user interface and data archiver. The data archiver is responsible for formatting and writing data to long term storage. The command processor

maintains the commanded state of each subsystem as well as formatting commands transmitted to subsystems. The input/output manager transforms packets to application data and transmits commands to the subsystems. The GUI manager is responsible for maintaining user interface state and partitioning user interface concerns from data processing. **Figure 48** describes the static structure of the VCU application using UML class diagram notation.

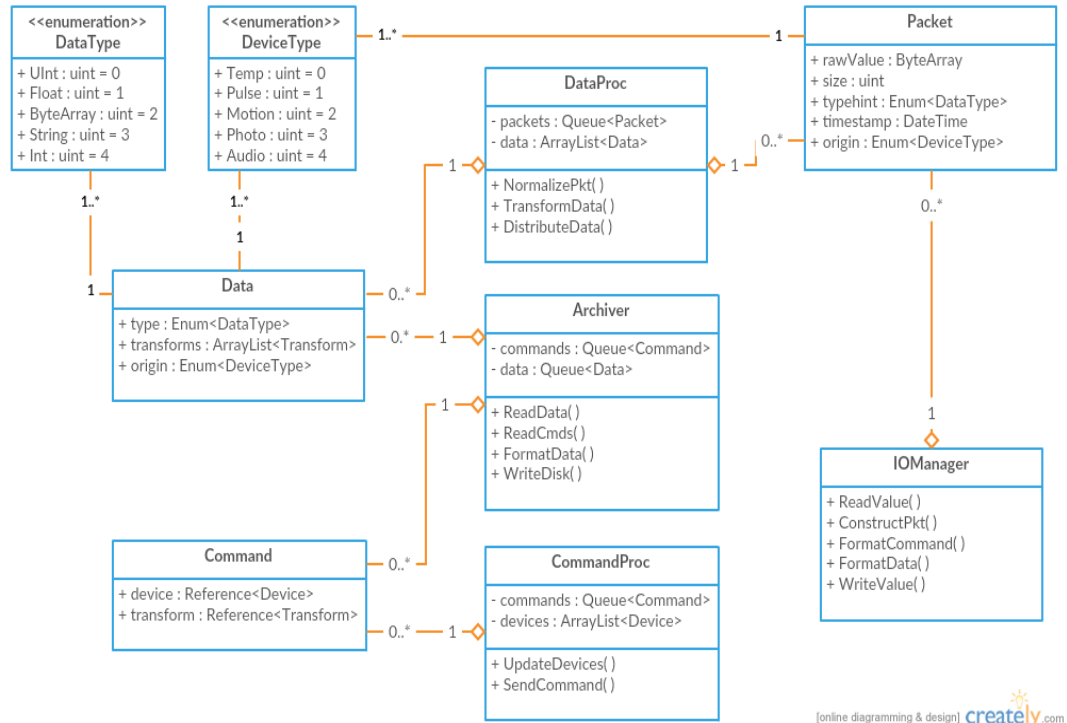

Figure 48 - VCU class diagram

Figure 49 describes a snapshot of dynamic activity of the VCU application using UML sequence diagram notation. In particular, the following sequence diagram describes the sequences of actions taken to process sensor data in the VCU.

VCU Data Processing Sequence

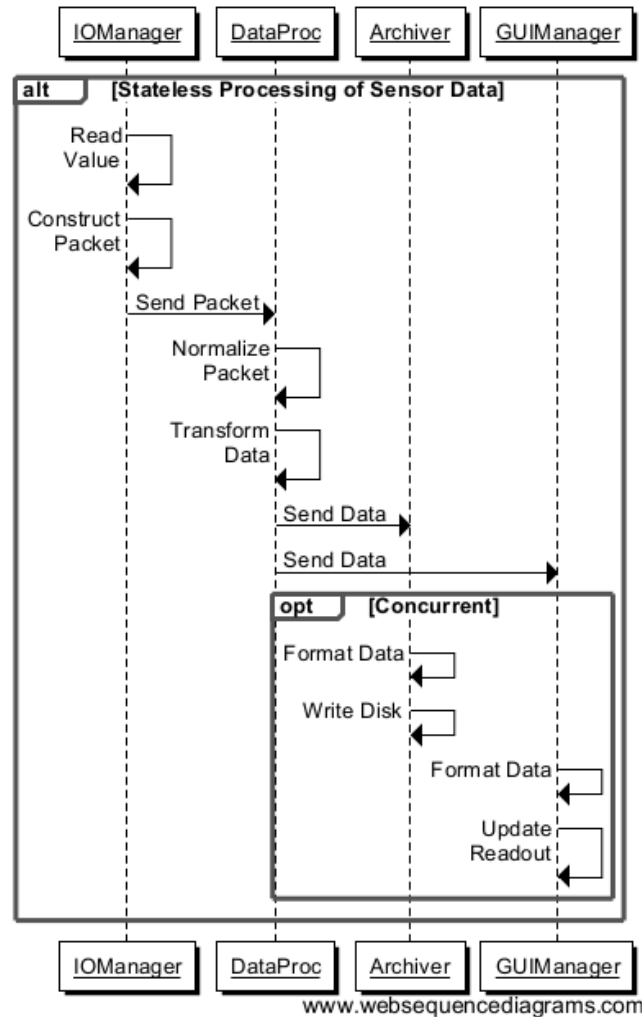

Figure 49 - VCU Data Processing

The VCU graphical user interface presents sensor data in engineering units as readouts and dynamic graphs. Additionally, the GUI presents device status and supervisory control of each subsystem. The GUI is statefull and managed by a persistent GUI manager object in the VCU application. The interface elements are built using the Android standard interface components and the GraphView dynamic graphing library. The Eclipse integrated development environment provides a solution to place interface components in a simplistic design tool. Other interface concerns are addressed programmatically for example updating graphs with sensor data values at 10 Hertz. Unless otherwise noted, all user interface code is written in the Java programming language and is not intended to be portable. The state of supervisory commands is maintained in the VCU application by a persistent command processing object. For example, the set point of the cooling system is monitored and adjusted by actions taken by the command processing object. User interface objects only maintain the state of user interface components not the backend processing of data and device state.

Unless otherwise stated, all user interaction with the VCU application is by a touch enabled Android smartphone.

The graphical user interface is logically partitioned into three general functions. The main display presents the user with three functions activity, status, and alarms. The user chooses a function and is presented with a display specific to that function. The activity display provides the user with dynamic graphs of subsystem sensor data and a graph of the user's sleep activity over time. Items on the graph can be shown and hidden by push buttons on a menu bar at the top of the display. **Figure 50** presents a storyboard of the activity display.

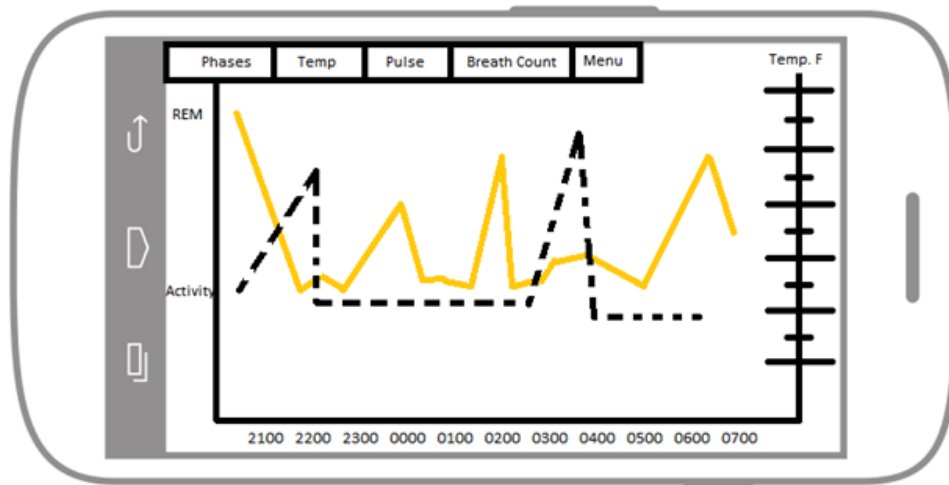

Figure 50 - Activity display

The status display presents the user a set of readouts for each subsystem and all supervisory controls. The status display is tabular enabling the user to select the subsystem of interest. The cooling tab of the status display allows the user to set the temperature of the cooling system. The cooling system can be turned on and off but defaults to on. **Figure 51** presents a storyboard of both the main and status display.



Figure 51 - Main and status displays

The alarms display presents the user a set of controls for setting alarms. The system will generate an audio based alarm to wake the user when particular average threshold values are met. For example, if the user’s respiratory rate falls below the average acceptable amount for a grown adult, the system generates an audio alarm. The alarms display presents the user controls to configure alarm thresholds and choose the audio alarm. **Figure 52** presents a storyboard of the alarms display.

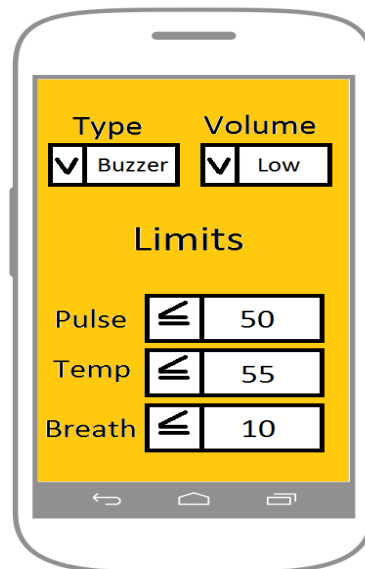

Figure 52- Alarms display

Each subsystem program shares similar concerns. The subsystem program must read sensor data from a peripheral device or analog-to-digital interface and convert the data into a shared structured data type. The sensor data is encapsulated and transmitted over USB to the VCU. Additionally, the subsystem program may do automatic process control. The process control algorithm takes parameters and can be reset and suspended. Every periodic update of the control algorithm produces a control signal transmitted to a device. The control software sends a control signal to a device input/output software component that formats the signal and handles communication with the device. Each subsystem depends on the VCU to do data archival. Unless otherwise stated, each subsystem shares a common codebase in the C programming language. The microcontroller manufacturer STMicroelectronics provides specialized software development tools such as compilers, assemblers, and debuggers to enable programming of the MCUs. The Knight Nite software requirements assume the program as designed will be appropriately sized for both static and dynamic MCU memory. **Figure 53** describes the static structure of each subsystem program using UML class diagram notation.

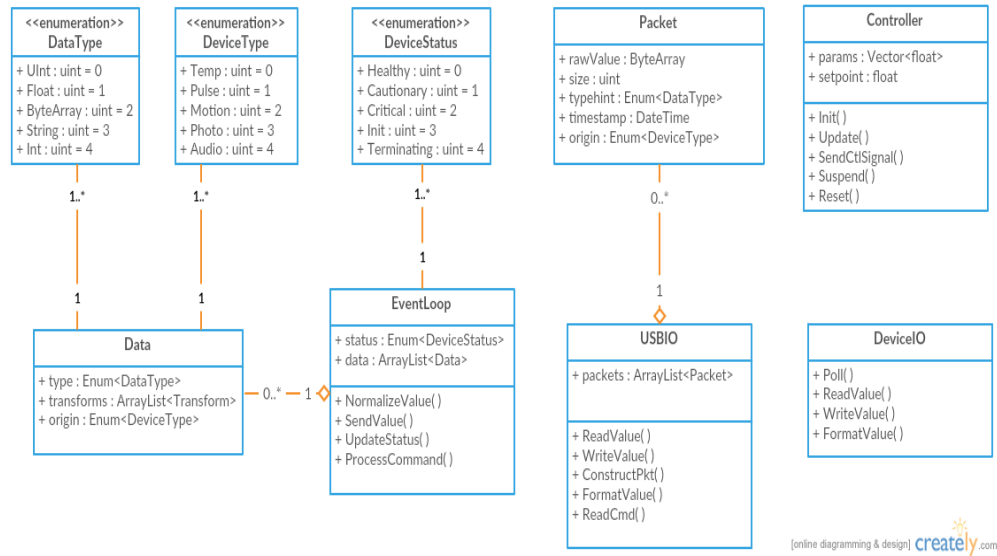

Figure 53- Subsystem class diagram

Figure 54 describes a snapshot of dynamic activity of a subsystem program using UML sequence diagram notation. The following sequence diagram shows the sequence of actions taken to do automatic control.

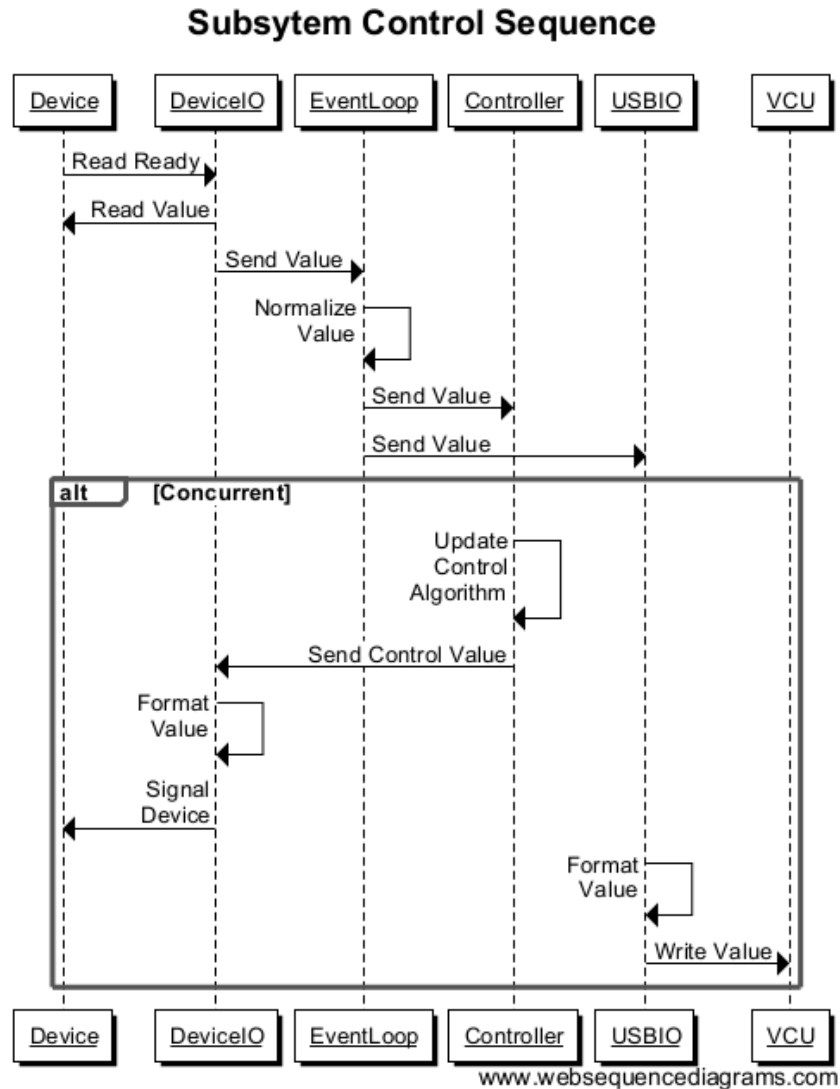

Figure 54 - Subsystem Control

10. System Implementation

10.1 Motion Sensor

There are multiple ways to monitor the movement of the human body during sleep. One popular way to implement a sensor to measure this is a gyroscope. These devices are not affected by the earth's gravity. They strictly measure angular velocity and come with multiple directions in measure. They can either monitor in 1 axis all the way up to 3 axes. They are very popular for anti-roll devices. Although they can monitor the motion of a sleeping patient, they are not a popular option due to the performance and traits of an accelerometer used with a microcontroller.

An accelerometer was chosen to monitor the movement of the user during sleep. Although an accelerometer only measures acceleration, movement of the user will constantly be tracked due to the gravitational forces of the earth. The MPU6050 will be implemented in the design. There are accelerometers on the market that monitor movement in x, xy, or xyz directions. The MPU6050 measures in all 3 directions which can be compared to accelerometers in most of today's smartphones such as the iPhone.

Figure 55 is the implementation of the MPU6050 accelerometer that will be used in Knight Nite. There are 4 basic connections that are connected to the STM32 microcontroller. Pins 18 and 19 are ground and power, respectively. The two signal lines come out of 40 and 41. The MPU6050 outputs signals through SCL and SDA to be programmed in C within the STM32 microcontroller.

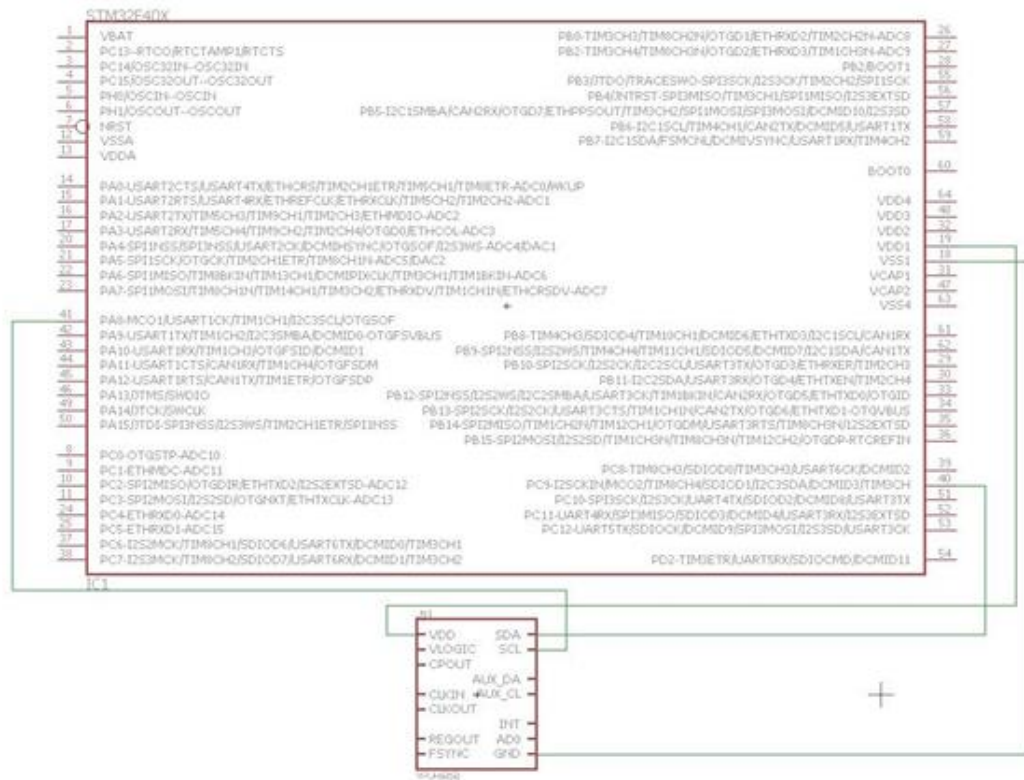

Figure 55 – MPU6050 with STM32

Figure 56 is a schematic of the MPU6050 broken all the way down to its passive elements. The accelerometer has a miniaturized microcontroller circuit of its own that will send digital signals of motion to the STM32 microcontroller.

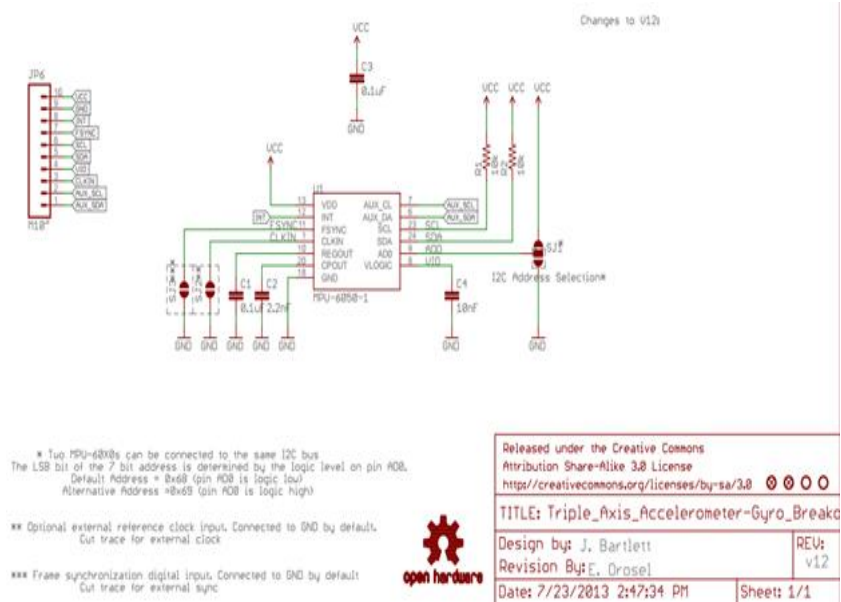

Figure 56 - MPU6050

The body motion sensor will be affixed to the head unit of Knight Nite. The data coming out of the accelerometer will be transmitted via a digital signal using the project made printed circuit board and STM microcontroller. Because the MPU6050 is compact in size and low in cost, it made it the prime choice for the motion sensor. Figure 57 is a Design Schematic by Jake Benedict implementing the MPU6050 with an STM32 microcontroller.

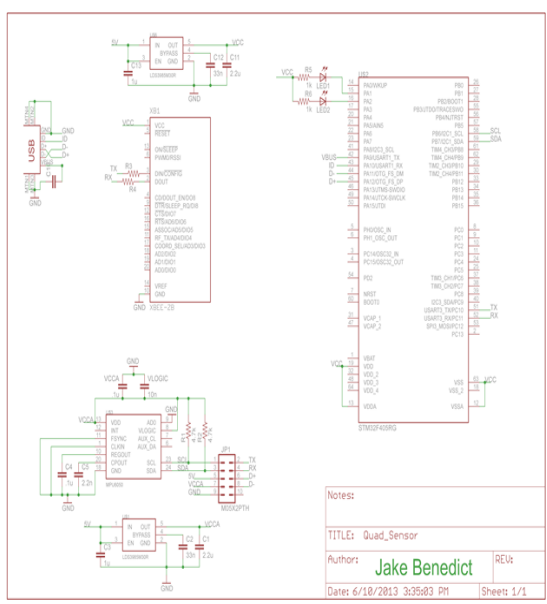

Figure 57 – MPU6050 implementation with STM32

10.2 Temperature Sensor

The STM32F40X microcontroller is used with the temperature sensor in order to monitor the forehead temperature of the user. Figure 58 shows the schematic of the temperature sensor and the microcontroller designed in the Eagle cad software. The sensor itself is simple in design and only features 2 signal pins and a pin for both ground and power.

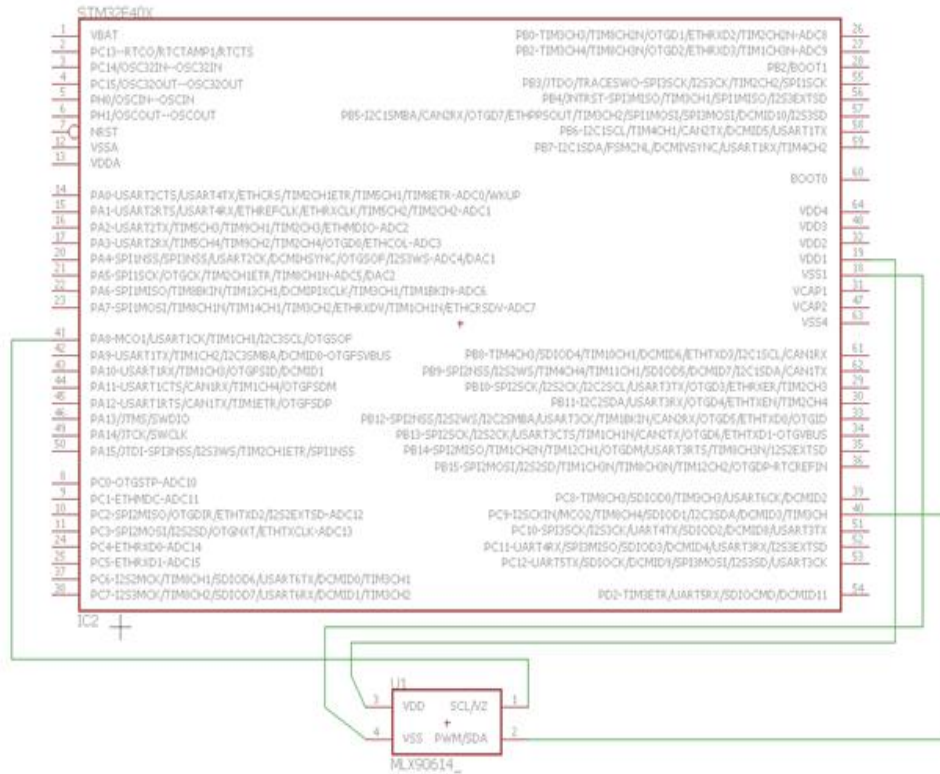

Figure 58 - Schematic of the temperature sensor

10.3 Heart Rate Sensor

The heart rate pulse sensor heart rate monitor will be implemented on a PCB and which contains a simple MCP6001 operational amplifier and several passive devices. Furthermore, the design will feature an APDS 9008 photo sensor that will run in conjunction with operational amplifier. This sensor will have the ability to output a digital signal to the project made printed circuit board which contains an STM32F4 cortex microcontroller. From this system, the microcontroller will be able to send the heart rate data to all other subsystems that may need to utilize the information. Figure 59 shows the schematic heart rate pulse sensor broken down to its active and passive components. The sensor can be built a simple operational amplifier. The schematic was taken directly from the pulse sensor website.

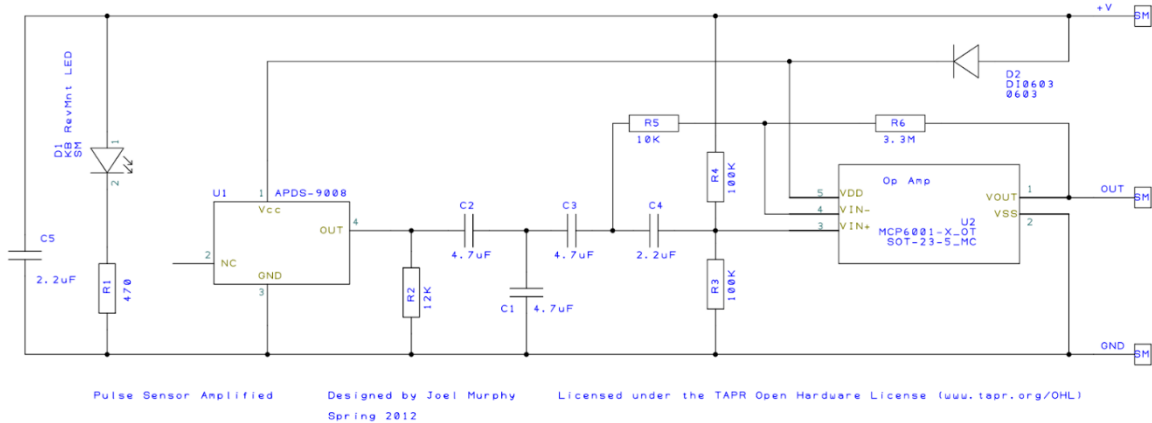

Figure 59 – Pulse Sensor Heart Rate monitor

10.4 Audio Sensor

Since the microphone is monitoring the user's breathing intervals, the audio system will convert the analog signal produced into a digital signal using the local analog to digital converter (ADC) channel of the MCU located within the audio subsystem. Following the low-pass filter, the signal will be passed through a full-wave rectifier to prevent negative voltage on the ADCs. Alternatively, the negative supply of the operational amplifiers may be grounded such that the output is between 0 and 3.3 volts. There are a few potential strategies for detecting the snoring with the microcontroller. One is to periodically read the signal through the ADC for a certain interval of time. Averaging the readings should be a good indicator of whether or not snoring took place during the measured interval.

Instead of constantly using the ADC over a certain interval of time, some resources might be saved using the peak detector circuit pictured in Figure 29. The idea is that the microcontroller reads from the peak detector output only once in the equivalent time interval instead of continuously reading. The peak level read will be a representation of the highest level of snoring during that time interval. The microcontroller will then apply voltage to the gate of the MOSFET to drain the capacitor so that new snoring peaks may accumulate. This may not be as detailed as averaging many values, so both methods will be tested.

The buzzer that will be used in this project is the MULTICOMP MCKP1206R1-4720 piezoelectric type buzzer. The MCKP1206R1-4720 has a wide range of frequencies that will allow for a variety of tones to be produced. This feature can give the designer the ability to manipulate the sound to a very pleasant tone or a very annoying tone for the deep sleepers. This buzzer is the most power efficient. It only consumed about 10 mW. The power consumption for the MULTICOMP MCKPI-G4510L-4013 was about 420 mW and the power

consumption for the PRO SIGNAL-ABI-001-RC was about 84 mW. The sound output for the MCKP1206R1-4720 is the loudest, which is rated at 115 dB. It also has the smallest dimensions compared to the rest of the buzzers.

10.5 Lighting

The lighting system will implement two distinct functions. One of the functions will be to collect light from the environment and convert that into data that a microcontroller can interpret. Figure 60 shows the implementation for the light detection system. The second function is to provide lighting for the user to wake up. The microcontroller will send a control signal to a relay that will switch power to LEDs to wake the user up. **Figure 61** depicts the implementation for the LED lighting.

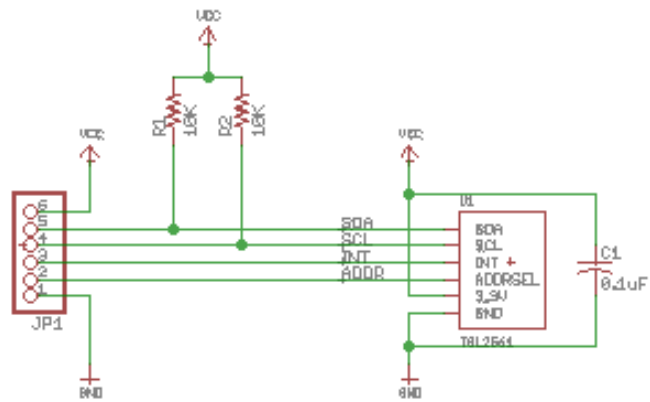

Figure 60 – Light Detection

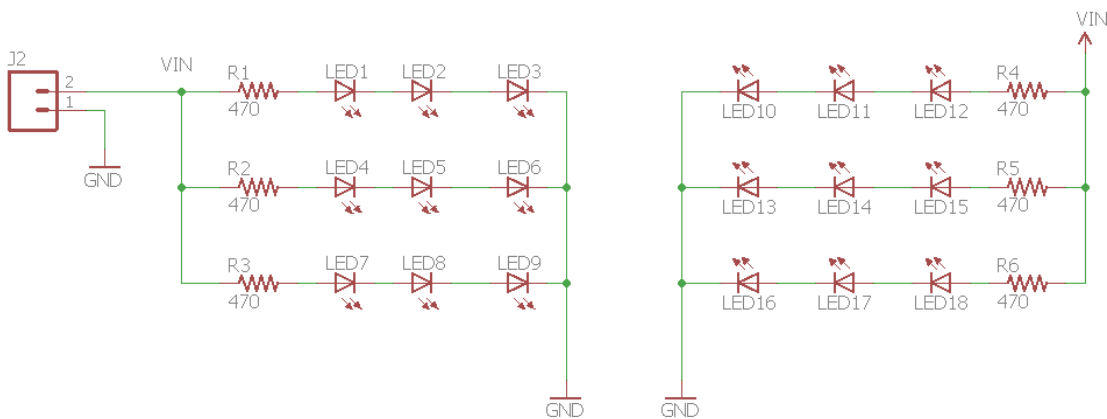

Figure 61 – LED Schematic

The LEDs will be incorporated into a single printed circuit board. The LED board will be mounted onto our head mount so that the LEDs are positioned to shine directly onto the user's eyes. The LED that will be used in this project is the WP710A10LBVC/D which is manufactured by Kingbright. This LED is the best choice because it offers a low forward current of 2 mA and costs \$0.31 each, which means less power consumption and low cost.

The LEDs will be powered using a 9V battery after a command is sent from our microcontroller. We decided to use a 9V battery to power the LEDs because it isolates the LED circuitry power and makes it easier to troubleshoot issues pertaining to the LEDs. In order to control when power is sent to the LEDs, we will use a solid state relay. The solid state relay used in this project will be the VOR114A6 manufactured by Vishay Semiconductors. The VOR114A6 was chosen because it has a low forward current of 0.27 mA and a fast turn-on time of 0.13 milliseconds. Once the solid state relay receives the control signal from the microcontroller, the LEDs will illuminate to wake the user up.

For ambient light detection, we will be using the TSL2561 Digital Lux sensor manufactured by Adafruit. This light sensor was selected for our project because it can capture a good range of light intensities from 0.1 to 40,000 Lux, and it has good accuracy when it comes to measuring light. The TSL2561 attaches to the main enclosure for our project and communicates to the lighting MCU using I2C communication protocol.

10.6 Printed Circuit Board

The printed circuit boards were designed and created in the program Eagle by Cadsoft. Because of its ease of use and availability to all students with a free license, it was the favorable program to use compared to other cad software. Furthermore, Eagle provided all of the hardware needed to implement the design schematics. Also, after designing the schematics the program will provide a suggested list of parts that are able to be purchased online. Although the program is free to use, there are some limitations to the freeware such as limiting the size of the board area and a six single layer limit.

Although there are many parts used in the schematic design, the freeware program provided by Eagle was a program that was more than enough to create PCBs for Knight Nite effectively. After finishing the actual board, parts will be ordered separately from the board in order to save money. Parts will either be soldered on by the group or taken to a fabricating company in Orlando Florida to be put together at low cost. Since Eagle does not include every part on the market, a significant amount of research needed to be done in order to find the library files for specific parts.

Figure 62 illustrates the final LED printed circuited board design used in Knight Nite.**Figure 62 LED PCB Layout**

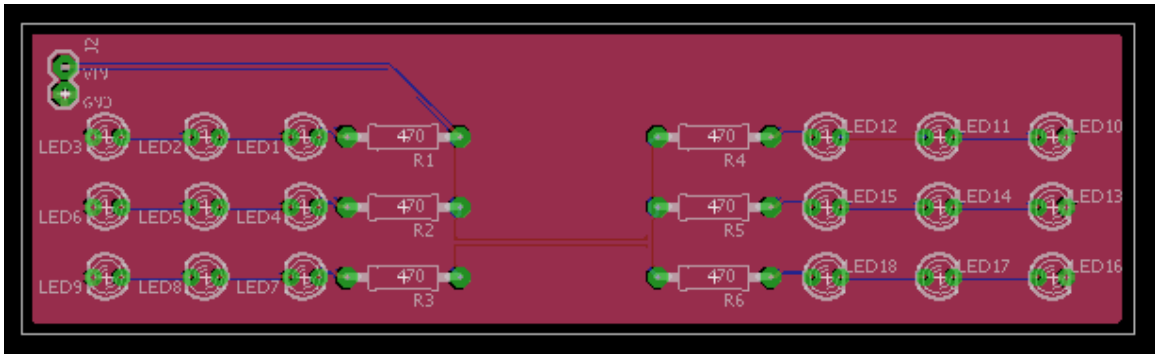

Figure 62 LED PCB Layout

Figure 63 illustrates the final power printed circuited board design used in Knight Nite.**Figure 62 LED PCB Layout**

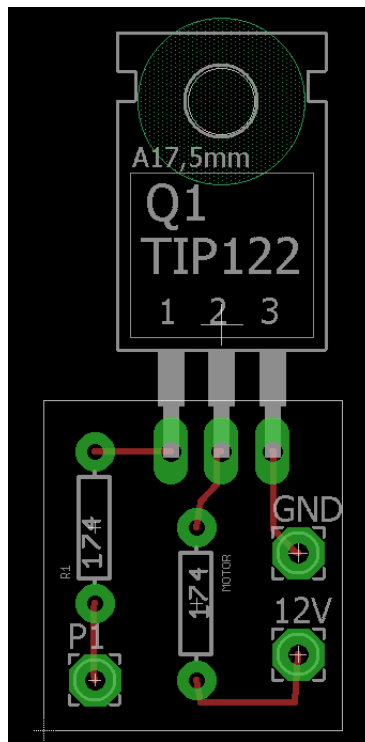

Figure 63 Power PCB Layout

Figure 64 illustrates the final MCU printed circuited board design used in Knight Nite.**Figure 62 LED PCB Layout**

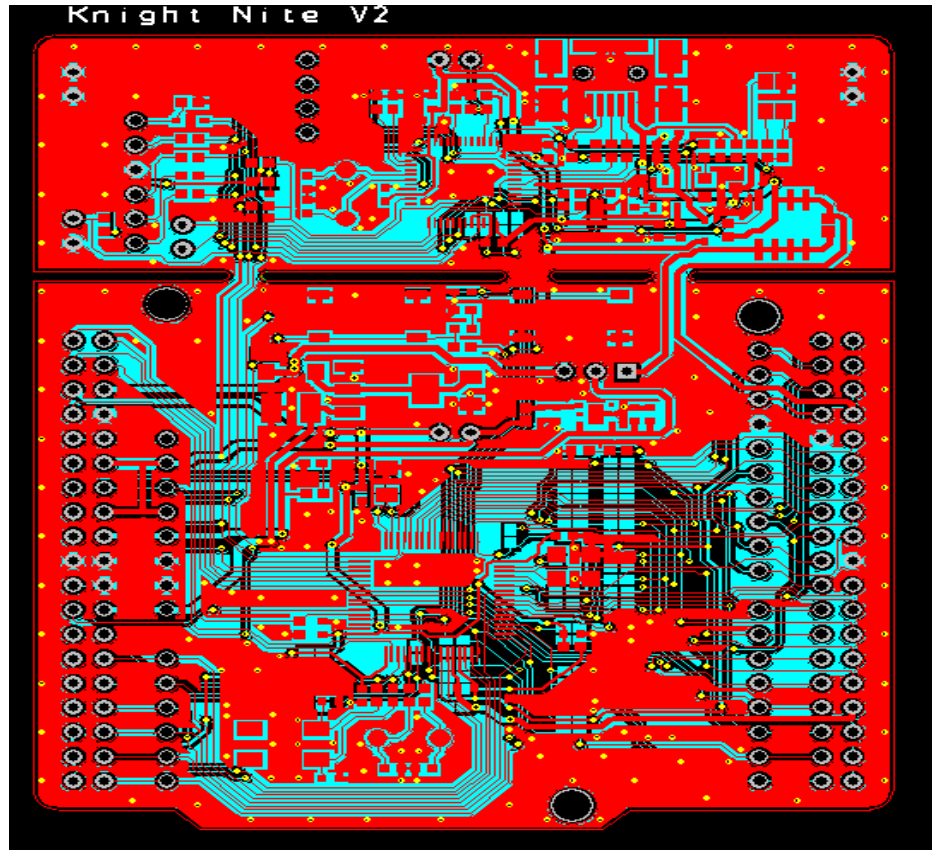

Figure 64 Final MCU PCB Layout

11. Testing

Functional testing is a testing methodology is typically broken down into four components - unit testing, integration testing, system testing and acceptance testing, usually executed in this order [14]. In order to assure complete functionality within this project, each system will have to be thoroughly tested by using thorough and efficient test plans, the team will follow some testing methodologies used in the industry.

Unit testing will test the individual software modules or components that make up a system. .Integration testing will test the different components that have been successfully unit tested when integrated together to perform specific tasks and activities. This testing will be done manually depending on how much time needed to create automated tests for specific integrated components. System testing will test the entire system for errors and bugs, by interfacing the hardware and software components of the entire system and then testing it as a whole. Acceptance testing is the final phase of functional software testing and involves making sure that all the project requirements have been met and makes sure it operates as expected and meets all our defined requirements.

Hardware will be one of the most important and valuable parts of this project. The hardware components will demonstrate the quality of the final product. For instance, imagine a scenario where a system fails and stops working. The user would have to replace the old system with an entire new system in order to fix the issue. A hardware design mistake will eliminate the project's quality and reliability. If someone were to buy a new laptop from an electronics store and for some strange reason the laptop stops working unexpectedly, he or she would have to contact the manufacturer to replace it. The customer could not repair it otherwise, unless there is a laptop technician available in the store. Even though most customer chooses to use the warranty, most manufacturers will send them a new one since it could take weeks to solve issue. A design flaw or malfunctioning of a component in hardware are very costly and pose a major financial risk. Figure 65 illustrates the Knight Nite prototype in the beginning phases of testing.

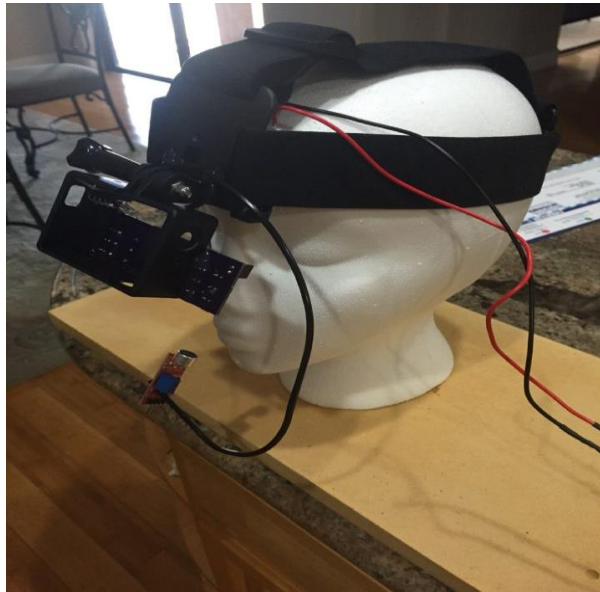

Figure 65 Prototype Testing

11.1 Vital Systems

Table 29 details how the unit tests should confirm that the temperature sensor can successfully obtain temperatures in standard operating circumstances and in ad-hoc situations. Table 30 details how the unit tests should confirm that the heart rate monitor meets the functional requirements. The monitor should obtain semi-accurate readings from a person.

Table 29 - Temperature Sensor Unit Testing

Step	Procedure	Expected Results
1. Determine Accuracy	<p>Obtain reading from low temperatures (65°F)</p> <p>Obtain reading from room temperatures (73°F)</p> <p>Obtain reading from high temperatures (98°F)</p>	± 1°F compared to digital thermometer
2. Determine Behavior in Ad Hoc Situations	<p>Obtain reading after sensor being submerged in bed sheets.</p> <p>Obtain reading in a cold environment.</p> <p>Obtain readings in a humid environment.</p>	± 1°F compared to digital thermometer

Table 30 - Heart Rate Sensor Unit Testing

Step	Procedure	Expected Results
Determine Accuracy	<p>Obtain reading from no heart rate. (disconnected)</p> <p>Obtain reading from resting state.</p> <p>Obtain reading from high heart rate. (170 bpm)</p>	20% error against Third-party High- Precision IMU
Determine Behavior in Ad Hoc Situations	<p>Obtain readings after being actively disconnected.</p> <p>Obtain readings from extreme low and high heart rates.</p>	The alarm might sound given

11.2 Audio System

The overall design involves acquiring sound with a microphone, this sound is then processed to detect breathing intervals. When the user goes longer than 15 seconds without breath, an alarm is sounded. The system may provide a warning when breathing rate increases/decreases outside normal levels. Table 31 details how the unit test should confirm that the microphone system responds appropriately to standard operating situations and ad-hoc situations.

Table 31 - Audio Unit Testing

Step	Procedure	Expected Results
Determine Frequency Range	Obtain reading under normal sleep condition Place system a few meters away from the user. Obtain reading after under normal sleep condition. Obtain reading as the user deliberately moves while sleep.	10% error against control
Determine Behavior in Ad Hoc Situations	Obtain reading while music is playing in the background. Place the microphone underneath a comforter, and obtain reading.	Still functional after procedures

11.3 Lighting Systems

The lighting systems has two parts that need to be tests. The first part consists of the photodetectors, which will be used to measure ambient light in the room. The second part is the LEDs that will be used to generate light in order to wake the user up.

11.3.1 Photodetector Testing

The photodetector portion will be made up of four phototransistors. Each phototransistor will be tested individually in six different lighting conditions. The conditions will be bedroom lighting, darkness, moonlight, light from liquid crystal

display (LCD) screen, light from a reading lamp, and light from an adjacent hallway. For each condition, a voltmeter will be used to measure the voltage across the phototransistor.

The first lighting condition will be in a bedroom with the main light on. Next, the photodetectors will be tested in a bedroom with the lights are turned off and the window blinds are completely shut. For moonlight testing, the window blinds will be opened about halfway. After measuring the voltage with the windows halfway, the window blinds will be opened to allow the most moonlight in the room and voltage will be measured again. At this point, the room will be returned back to full darkness. One LCD monitor will be turned on, specifically a television screen. The voltage will be measured and the LCD screen will be turned off.

The same process for testing the LCD screen will be used to test the reading light. The final testing condition is light coming from a nearby hallway. For hallway condition, the bedroom will be returned to complete darkness, meaning all lights will be shut off and the window blinds will be fully closed. The room door will be opened about halfway (45 degrees). The reasoning behind using 45 degrees is to simulate a person, such as a roommate, opening the door. Majority of the time, roommates usually do not open the door completely if they want to ask a quick question or see if the user is home.

After individual testing, all of the photodetectors are connected together do some integration testing. A microcontroller will receive four voltages corresponding to the four detectors, respectively. Then, test the entire photodetector unit is tested in each of the six lighting conditions shown in Table 32.

Table 32 - Lighting Unit Testing

Step	Procedure	Expected Results
Determine Accuracy	Obtain reading in the following conditions: <ul style="list-style-type: none"> • bedroom lighting darkness • Moonlight • light from liquid crystal display (LCD) screen • light from a reading lamp • light from an adjacent hallway 	Using a multimeter to measure the voltage across the phototransistor
Time Domain Response	Using an oscilloscope, measure the time domain response of the photodetectors	

11.3.2 LED Testing

A signal generator will be used to test the LEDs. Using the signal generator, a 5 volt DC signal will be placed across each LED. The goal of this test is to observe whether or not the LED lights up. Once all LEDs have been individually tested, all LEDs will be powered at the same time using the same 5 VDC signal. The next step is to test the LEDs with a microcontroller. The microcontroller will send signals to turn the LEDs on for one cycle and off for another cycle. This sequence will be executed twice to ensure that there is good communication between the LEDs and microcontroller shown in

Table 33.

Table 33 - LED Testing

Step	Procedure	Expected Results
Functional Test	Apply a 5 V DC signal to each LED Connect all the LEDs together and apply the same voltage	LED should light up
Signal Control Test	Connect the LEDs to the local MCU in the subsystem. From the MCU send a signal to the LEDs	LEDs should turn on and off in sequence

11.4 Cooling System

Table 34 details how the unit test should confirm that the cooling system properly lowers the temperature. The team will heat objects to different high temperatures and monitor the time it takes for the system to drop the object's temperature down the desired temperature. The cooling system needs to be able to run for a long period of time based on a standard sleep cycle of 8 hours. Although the system may not be in use for 8 hours, the pump needs to be able to run for 8 hours in case the user's forehead keeps on fluctuating in temperature. Furthermore, the cooling system must not leak and should be tested for any kind of leaks in the pump or in the cooling lines as well.

Table 34 – Cooling system Testing

Step	Procedure	Expected Results
Functional Test - Measure the temperature of items before and after the system is applied	Heat item to desired temperature and record it. Apply the system to the item for three minutes	After three minutes, measure the temperature of the items
Determine Behavior in Ad Hoc Situations	Conduct the functional test procedure above in a hot humid room	

11.5 Power Unit Testing

Table 35 details how the unit tests should confirm that the power requirements for the predicted power intake of all the components within the subsystem are met. In addition, confirm that enough power can be supplied to all the components for at least 8 hours.

Table 35 – Power Unit Testing

Step	Procedure	Expected Results
Functional Test	Apply a load equivalent to each subsystem's load	Battery should supply enough power for 8 hours. Battery should not overheat.
Operating Temperature	While step 1 is being performed, obtain temperatures from the power supply.	Power supply should meet operating temperature requirements.

11.6 System Integration Testing

Table 36 details how the unit test should confirm that the components, major sensors, and the microcontroller within each subsystem were successfully integrated.

Table 36 - System Integration Testing

Step	Procedure	Expected Results
Single power integration	Connect power supply to a single component at a time	Each component should be powered.
Full power integration	Connect all the components to the power supply	All components should be powered.
Algorithm test	Perform a functional test on each subsystem.	Collect data from each component, form a new packet, and send the packet through the USB port.
Functional test	Run the completed system for 8 hours.	Data should be collected, processed, and sent for 8 hours straight without loss of power or faults.

11.7 User Interface

The user interface subsystem will undergo a mixture of nonfunctional and functional tests, in order to ensure the software meets requirements and check the overall quality of the system. In this project, the user-interface will undergo functional tests to confirm that its back-end meets functional requirements shown in Table 37. On the other hand, non-functional tests will confirm that the user interface is easy-to-use and contains good visual aesthetics.

Table 37 - User Interface Testing

Step	Procedure	Expected Results
Main display push button	Push each of Activity, Status, and Alarms push buttons	Activity push button causes activity display to show. Status

test		push button causes status display to show. Alarms push causes alarms display to show
Status display tab test	Push each of Cooling, Audio, Vital, and Light tab selects	Each tab select causes the status display body to update with appropriate subsystem readouts and controls shown.
Status display audio readouts test	Select audio status tab on status display. Generate an audio signal at the audio subsystem.	Status display audio tab readouts update with values.
Status display vital readouts test	Select vital status tab on status display. Generate signals at each of vital sensor pulse, motion, and temperature.	Status display vital tab readouts update with values.
Status display light readouts test	Select light status tab on status display. Generate signal at photo sensor.	Status display light tab readouts update with values.
Status display cooling readouts test	Select cooling status tab on status display. Generate signal at temperature sensor.	Status display cooling tab readouts update with values.
Status display cooling controls test	Select cooling status tab on status display. Adjust cooling system setpoint.	Status display cooling tab readouts update with values. Control algorithm status readout indicate active status.
Activity display dynamic graphing test	Push activity button on main display. Select phases and temp menu bar.	Activity display dynamic graph updates periodically with inferred sleep phase values and temperature values.
Alarms display controls test	Push alarms button on main display. Set each of pulse, temperature, and breathe control values.	

Alarms display alarm test	Push alarms button on main display. Set threshold temperature alarm limit select control to a low of 60 degrees and then high of 100 degrees.	Buzzer alarm audio is generated at each of 60 degrees temperature reading and 80 degrees temperature reading.
Alarms display buzzer test	Push alarms button on main display. Set threshold alarm limit select control to room temperature. Select of each of audio volume low, medium, and high.	Buzzer alarm audio is generated at low, medium, and high volume.

11.8 Complete Integration

Once the main parts of the project are tested, i.e. the hardware, the user interface, are data communication are ready to be integrated and receive a final system test. This portion of testing will be the last safety-net before the bugs are caught before being released out to the public. The method of testing used will be regression testing. Hence, previous unit tests will be performed again. Once the regression testing is done, it will be followed by a system test; hence, the system will be used just as how the end-user would use it shown in Table 38.

Table 38 - Regression Testing

Step	Procedure	Expected Results
Integrate All Subsystems	Integrate the hardware with wired subsystems. Hereafter, integrate the wired subsystems with the user interface.	
Functional Test - Hardware	Perform main functional test on hardware components.	Same result as previous functional tests performed on the hardware.
Functional Test – User Interface	Perform main functional test on software modules.	Same result as previous functional tests performed on the user interface.
Functional Test - Data	Perform main functional test on software modules.	Same result as previous functional tests performed

Communication		on the communications.
---------------	--	------------------------

12. Milestones

Project management is an often forgotten but essential aspect to any successful project. Over the next several months, this project will be broken down into achievable milestones spanning two semesters. In order to better manage the project, the milestones will the team to complete the work without overwhelming the any team members.

Each milestone in this project will be given between two and three weeks to be completed. Some of the difficult milestones may take longer but it will build on previous milestones through weekly meeting and having such a short time frame for each milestone will allow the team to focus on each milestone. Extending milestones is not ideal with such a short timeline to complete the project, but under special circumstances some milestones might be extended upon group discussion.

Research and testing are the main focus during the first semester of Senior Design. The team must learn the background information relevant to the project and complete the upcoming milestone. Research will take up a bulk of time during the first semester. As the research on going, the team will keep notes important to each part of the project in order to determine the best fit for the design specifications. The team is doing this to completely understand what needs to be done for each section and time needed to complete it. Table 39 was created to display the team's milestones during the first semester of senior design.

Table 39 - Senior Design 1 Milestones

Initial	Identify project and requirements
January	Form group and agree on a project idea
	Complete 5-10 page divide and conquer
February	Majority of requirements identified, each group member knows their role
	Each member has in depth research of similar products for their part have a near full 90% completed table of contents

March	At least 2 propositions for funding
	Major and Sub design components (high level)
	Each member will provide a list of components we plan to use for each device
April	Build of Materials (parts list) after having a complete design
	Design a prototype
	All documentation/schematics complete
	Have parts ordered in order to have them ready by the beginning of the summer semester
End of Spring Semester	Complete Design Layout, Funding Completed
Beginning Summer Semester	Completed Design Plan/Layout and Materials

During the second semester of senior design, the team will finish developing a prototype, integrate the subsystems in to the prototype, design software, order materials, design PCBs, and conduct testing.

Ordering all the required parts will be first priority in the first few weeks in order to finish the hardware prototype. Once that is complete, the software development can begin. Upon completion of the prototype, it will essential to start ordering parts for the final PCBs. The cheapest parts come from most online electric part vendors outside of the country, and may add more time it will take for the parts to arrive. Making it necessary to place the order right after completing the prototype. Table 40 displays the milestones for the team during the second semester of senior design.

Table 40 - Senior Design 2 Milestones

May	start building and implementing test plans for sub components
June	completed project ready for testing

	Analyze performance of each test
	Fix any bugs or issues with the design
July	completed project with presentation and results

12.1 Budget and Financing

Most the components were discussed above apply towards usage and implementation to the project. However, there are several other costs not involved in the development, prototyping, and fabrication of the project. In order to accurately reflect the costs associated in the project's budget a bill of material was created. **Error! Reference source not found.** displays the pre-planned costs in the Bill of Materials given the project's budget.

Some items may not appear in the final prototype, and small negligible prototyping components are not included as well. Some required test bench equipment as oscilloscopes, function generators, multimeters are made available from the University of Central Florida. Costs of fabricating PCBs and software license fees will be included in the project's budget. The overall budget is projected and should remain under \$1,000.00, even with unforeseen circumstances. Currently, this project is not sponsored as of yet, but hopefully during Senior Design II that will not be the case.

Part	Cost
usb hub	22
microphone goom neck	11.28
mpn transistors	2.99
Cooling block	7.11
Peltier Pad	3.99
Thermal Paste	4.47
Peltier Heat Sync	8.23
Go Pro Head Strap	4.68
Microphone Senesor	4.49
Pulse Heat Sensor	5.85
Hco5 Bluetooth	8.99
audino Mega2560	21.99
breadboard with cables	12.99
head	4.3
usb micro b cables	8.29
water pump	11.99
ST Link Debugger	22.61
3 STM32 Dev boards (1 was credit back)	40
PCB Components MCU	68.45
Cooling PCB	3.8
MCU PCB	14.75
Audio PCB	14.5
Lighting PCB	43.95
Go Pro Head Mount	5
Solid state relay	2.00
Blue LEDs	5.88
9V Alkaline Battery	2.74
9V Battery Holder	1.70
Digital Light Sensor	5.95
1A 30V Rectifier Diode	0.32
1/4 Watt 180 ohm Resistor	0.14
1/4 Watt 470 ohm Resistor	0.98
JTag Arm Adapter	7.08
Box	13
Total	396.19

Figure 66 BOM for Knight Nite

The following tables and figures consists of the bill of materials list that will be need to be bought in order to start building Knight Nite. There are many passive components that will be bought in bulk in order to save money and keep the project's finances in check. Furthermore, some of the more complicated active components will need to be bought at certain locations that are unique to that part.

1	Part	Manufacturer	Part Number	Quantity	Price
2	Cdd	Nichicon	UVR1V100MDD1TA	1	0.03
3	Cdd2	Nichicon	UVR1V100MDD1TA	1	0.03
4	Cin	CUSTOM	CUSTOM	1	0
5	Cin2	CUSTOM	CUSTOM	1	0
6	Cout	Panasonic	16SVPF560M	2	0.61
7	Cout2	MuRata	GRM155R61A104KA01D	1	0.01
8	Cs	MuRata	GRM21A5C2E101JW01D	1	0.03
9	D1	ON Semiconductor	1N4937G	1	0.04
10	D2	Diodes Inc.	B230A-13-F	1	0.09
11	D3	Rohm	RF071M2S	1	0.092
12	Dac	Diodes Inc.	HD04-T	1	0.12
13	Dz	ON Semiconductor	1SMB5949BT3G	1	0.1
14	L1	Bourns	SDR0403-102KL	1	0.18
15	L2	Bourns	SDR0403-102KL	1	0.18
16	NTC	Ametherm	SL0310001	1	0.23
17	Rbld	Vishay-Dale	CRCW040212K4FKED	1	0.01
18	Rcs	Vishay-Dale	CRCW04021K74FKED	1	0.01
19	Rdd	Vishay-Dale	CRCW040233R2FKED	1	0.01
20	Rf1	Yageo America	RC1206FR-076K8L	1	0.01
21	Rf2	Yageo America	RC1206FR-076K8L	1	0.01
22	Rfbb	Vishay-Dale	CRCW040244K2FKED	1	0.01
23	Rfbt	Panasonic	ERJ-6ENF2003V	1	0.01
24	Rs	Panasonic	ERJ-8ENF1501V	1	0.01
25	Rs2	Vishay-Dale	CRCW0402130KFKED	1	0.01
26	T1	Core=TDK , CoilFormer=TDK	Core=B65841A0000R087 , CoilFormer=B65842W1008D002	1	0.743
27	U1	Texas Instruments	UCC28911D	1	0.98
28				Total Cost	3.555

Figure 67 - BOM for AC Power Supply PCB

1	Attribute 1	Value	Attribute 2	Value	Attribute 3	Value	Footprint
2							CAPPR2-5X11
3							CAPPR2-5X11
4							CUSTOM
5							CUSTOM
6							CAPSMT_62_E12
7							402
8							805
9	VFatIo	1.2V	Io	1A	VRRM	600V	DO-41
10	VFatIo	0.5V	Io	2A	VRRM	30V	SMA
11	VFatIo	0.85V	Io	1A	VRRM	200V	SOD-123
12	VFatIo	1V	Io	0.8A	VRRM	400V	MiniDIP
13	VRWM	100V	DCWatts	0.55W	VRSM	0V	SMB
14	L	1mH	DCR	14Ohm	IDC	0.09A	SDR0403
15	L	1mH	DCR	14Ohm	IDC	0.09A	SDR0403
16	Resistance_25C	100Ohm	Bref_T1_T2	0	Resistance_Tol_pct	20%	SL03
17	Resistance	12.4kOhm	Tolerance	1%	Power	0.063W	402
18	Resistance	1.74kOhm	Tolerance	1%	Power	0.063W	402
19	Resistance	33.2Ohm	Tolerance	1%	Power	0.063W	402
20	Resistance	6.8kOhm	Tolerance	1%	Power	0.25W	1206
21	Resistance	6.8kOhm	Tolerance	1%	Power	0.25W	1206
22	Resistance	44.2kOhm	Tolerance	1%	Power	0.063W	402
23	Resistance	200kOhm	Tolerance	1%	Power	0.125W	805
24	Resistance	1.5kOhm	Tolerance	1%	Power	0.25W	1206
25	Resistance	130kOhm	Tolerance	1%	Power	0.063W	402
26	Lp	1.295mH	Npri	71	Leakage_L	15.541uH	TDK_B65839
27							D0007A

Figure 68 - AC Power Supply BOM Attributes

Part	Manufacturer	Part Number	Quantity	Price	Attribute 1	Value	Attribute 2	Value	Attribute 3	Value	Footprint
Ccomp1	Yageo America	CC0805KRX7R9BB272	1	0.01							805
Cdd	MuRata	GRM31CR71H475KA12L	1	0.07							1206
Cfb3	Taiyo Yuden	TMK212B7473KD-T	1	0.01							805
Cin	MuRata	GRM55DR72E105KW01L	3	0.26							2220_200
Cin2	MuRata	GRM55DR72E105KW01L	3	0.26							2220_200
Cout	Panasonic	165VP330M	1	0.39							SM_RADIAL_10AMM
Cout2	Panasonic	165VP330M	1	0.39							SM_RADIAL_10AMM
Cs	MuRata	GRM188R72E102KW07D	1	0.01							603
D1	Bourns	CD1408-FU1400	1	0.13	VFatIo	1.05V	Io	1A	VRRM	400V	Diode_1408
D2	Diodes Inc.	B220-13-F	1	0.08	VFatIo	0.5V	Io	2A	VRRM	20V	SMB
D3	Diodes Inc.	DFLS1200-7	1	0.21	VFatIo	0.85V	Io	1A	VRRM	200V	PowerDI123
Dac	Diodes Inc.	HD04-T	1	0.12	VFatIo	1V	Io	0.8A	VRRM	400V	MiniDIP
Dz	ON Semiconductor	15MB5952BT3G	1	0.1	VRWM	130V	DCWatts	0.55W	VRSM	0V	SMB
L1	Bourns	SDR0302-471KL	1	0.18	L	470uH	DCR	14.3Ohm	IDC	0.11A	SDR0302
L2	TDK	MLP2012S1R0MT051	1	0.12	L	1uH	DCR	0.208Ohm	IDC	1.5A	MLP2012S-M
M1	IXYS	IXTA06N120P	1	1.43	VdsMax	1.2kV	IdsMax	0.6A	Rdson	30.161Ohm	DDPAK
O1	California Eastern Laboratories	PS2811-1	1	0.384							SSOP-4
Rcs	Vishay-Dale	CRCW04022R74FKED	1	0.01	Resistance	2.74Ohm	Tolerance	1%	Power	0.063W	402
Rdd	Yageo America	RC0603FR-0722RL	1	0.01	Resistance	220Ohm	Tolerance	1%	Power	0.1W	603
Rfb3	Vishay-Dale	CRCW0402210KFKED	1	0.01	Resistance	210kOhm	Tolerance	1%	Power	0.063W	402
Rfb4	Vishay-Dale	CRCW0402220KFKED	1	0.01	Resistance	20kOhm	Tolerance	1%	Power	0.063W	402
Rfbb	Yageo America	RC0603FR-0743KL	1	0.01	Resistance	43kOhm	Tolerance	1%	Power	0.1W	603
Rfbt	Vishay-Dale	CRCW040243K2FKED	1	0.01	Resistance	43.2kOhm	Tolerance	1%	Power	0.063W	402
RfI	Vishay-Dale	CRCW040210R0FKED	1	0.01	Resistance	100Ohm	Tolerance	1%	Power	0.063W	402
RfIc	Vishay-Dale	CRCW04021K74FKED	1	0.01	Resistance	1.74kOhm	Tolerance	1%	Power	0.063W	402
Ropt	Vishay-Dale	CRCW04021K00FKED	1	0.01	Resistance	1000Ohm	Tolerance	1%	Power	0.063W	402
Rs	Vishay-Dale	CRCW04022K94FKED	1	0.01	Resistance	2.94kOhm	Tolerance	1%	Power	0.063W	402
Rs1	Vishay-Dale	CRCW0402137KFKED	1	0.01	Resistance	137kOhm	Tolerance	1%	Power	0.063W	402
Rs2	Vishay-Dale	CRCW040234K8FKED	1	0.01	Resistance	34.8kOhm	Tolerance	1%	Power	0.063W	402
RtI	Vishay-Dale	CRCW04021K10FKED	1	0.01	Resistance	1.1kOhm	Tolerance	1%	Power	0.063W	402
T1	Core=TDK , CoilFormer=TDK	Core=B66311G0000X127 , CoilFormer=B66206C1014T001	1	1.031	Lp	1.507mH	Npri	88	Leakage_L	18.085uH	TDK_B66305
U1	Texas Instruments	UCC28740DR	1	0.42							R-PDSO-G7
VR	Texas Instruments	TL431AIDBZR	1	0.08	IkMin	0.4A	ReferenceOutput	2.495Volts	InitialAccuracy	1%	DBZ0003A
			Total	5.815							

Figure 69 - BOM for DC power supply PCB

12.2 Design Summary

The objective of Knight Nite is to provide real sleep solutions along with sensible data that provides the user with a better night of sleep. Although there are many current devices on the market that monitor the sleep patterns of users, there are no devices that provide a solution for the user for a better night's sleep. Knight Nite features major subsystems that aid in helping the user fall asleep and stay asleep. It features major subsystems such as a cooling, lighting, and audio component that monitor and affect the user's behavior during sleep based on the inputs given via the user interface. Upon completion of the first semester of Senior Design, the overall project design has been completed with all the parts for the prototype phase.

The Knight Nite product is designed to be the real-time solution to users who are experienced difficulties with sleeping. The audience we want to address mainly are those people with sleeping disorders such as sleep apnea, insomnia and restless legs syndrome. The design of this complex system consists of several parts.

First there is an audio unit that will be implemented in order to do several things. One of the things that the audio system will do is monitors any sounds or noises that occur throughout the night while the user is trying to sleep. In order to record the sound from the environment, the audio system will be designed with a microphone that will utilize a bandpass filter in order to catch the correct sounds. As part of the control system for Knight Nite, the audio system will also be designed to generate sound to bring the user back to sleep in the event that they wake up in the middle of the night due to some random stimulus from the environment. Knight Nite will generate white noise because white noise has been shown to soothe the user to a calm state.

The next aspect of the design for our project is the lighting system. The lighting system is designed to do two things, detect light and generate light. Knight Nite is designed to use photodetectors to capture the light that is present in the environment of the user. The voltage from the photodetectors will then be passed through an analog-to-digital converter so that it can be sent to a microcontroller for processing and visualization. Light generation is achieved by the use of light emitting diodes (LEDs) incorporated into a sleep mask so that in the morning light can shine through the sleep mask and wake the user up. The project is designed to use LEDs to wake the user up because audio alarms have a tendency to wake users up in an abrupt manner, which interrupts the sleep cycle and makes it difficult to wake up in the morning. Knight Nite uses light to wake the user up because it is light is the natural trigger that is supposed to wake the human body up in the morning.

In addition, the Knight Nite system has a series of sensors for monitoring the vital response of the user. One of the sensors is a heart rate monitor. The heart rate monitor

gives us an idea of the quality of sleep the user is getting. If the heart rate is fast, the user is most likely in a more awakened state, but as the heart rate drops, the user is in a deeper level of comfort. Our project is also designed to monitor the breathing of the user using a microphone. A temperature sensor will be placed near the frontal lobe of the head to regulate the temperature of the forehead. The cooling unit is strategically placed near the frontal lobe because as the user falls into a deeper sleep, their body temperature is supposed to decrease. If the Knight Nite records a high temperature on the user's forehead, the system will activate the cooling unit in order to bring the forehead temperature down and improve the user's ability to go to sleep. Figure 70 illustrates the final prototype design of Knight Nite.

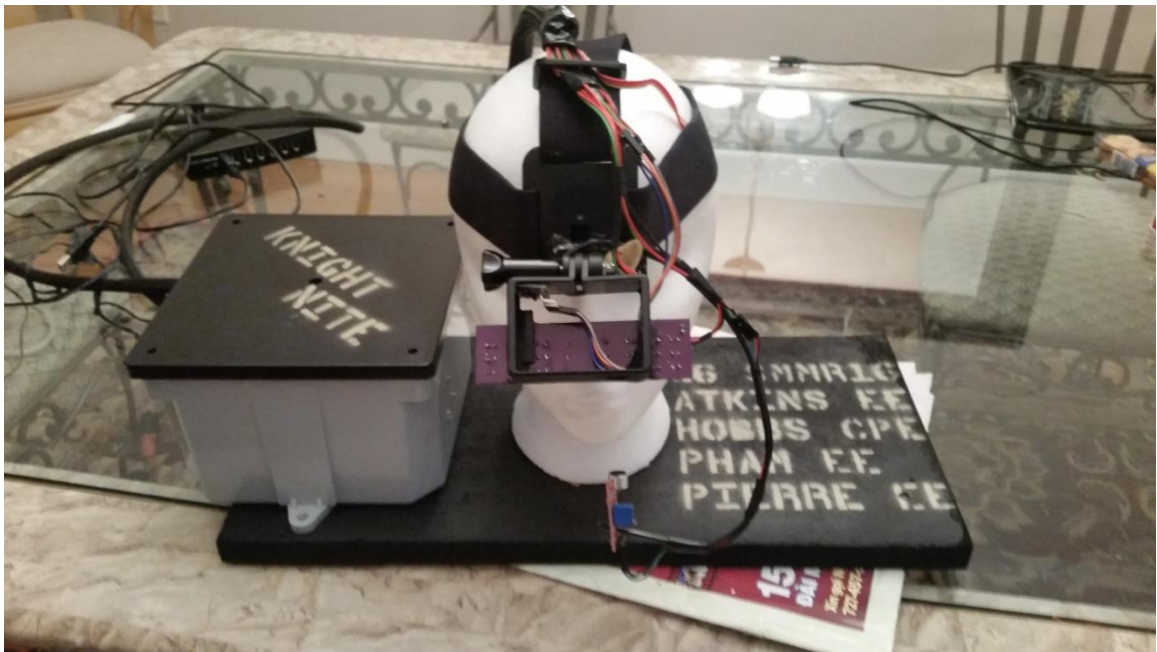

Figure 70 Final Knight Nite Prototype

13. Appendix

13.1 Permission to use content

Permission to use images/material

 **Hieu Pham** <hipham159@gmail.com> 7:04 PM (5 minutes ago) ☆
to sales_usa ▾

Good evening Melexis,

The Knight Nite senior design team here at the University of Central Florida is kindly asking your permission to use schematics and images of the MLX90614 in our senior design paper.

https://www.sparkfun.com/datasheets/Sensors/Temperature/MLX90614_rev001.pdf

All images and schematics would be cited appropriately.

Please let us know if this is possible. Thank you for your time!

Very respectfully,

Knight Nite Team

Permission to use images/material

 **Hieu Pham** <hipham159@gmail.com> 7:05 PM (5 minutes ago) ☆
to kim_freeman ▾

Good evening GE,

The Knight Nite senior design team here at the University of Central Florida is kindly asking your permission to use schematics and images of the ZTP 115 in our senior design paper.

<http://www.ge-mcs.com/download/temperature/920-550A-LR.pdf>

All images and schematics would be cited appropriately.

Please let us know if this is possible. Thank you for your time!

Very respectfully,

Knight Nite Team

Permission to use images/material

 **Hieu Pham** <hipham159@gmail.com> 7:06 PM (4 minutes ago) ☆
to pr ▾

Good evening Ivensense,

The Knight Nite senior design team here at the University of Central Florida is kindly asking your permission to use schematics and images of the MPU6050 in our senior design paper.

All images and schematics would be cited appropriately.



Please let us know if this is possible. Thank you for your time!

Very respectfully,

Knight Nite Team

Permission to use images/material



 **Hieu Pham** <hipham159@gmail.com> 7:07 PM (3 minutes ago) ☆ 
to ti-cares ▾

Good evening Texas Instruments,

The Knight Nite senior design team here at the University of Central Florida is kindly asking your permission to use schematics and images of the UCC28700 and TSP54336A in our senior design paper. We are also asking for permission to use the graphs generated by your program Webench online.

All images, graphs, and schematics would be cited appropriately.

Please let us know if this is possible. Thank you for your time!

Very respectfully,

Knight Nite Team

Permission to use images/material

 **Hieu Pham** <hipham159@gmail.com> 7:08 PM (2 minutes ago) ☆ 
to Joel ▾

Good evening Pulse Sensor,

The Knight Nite senior design team here at the University of Central Florida is kindly asking your permission to use schematics and images of the Pulse sensor unit in our senior design paper.

<http://pulsesensor.com/pages/open-hardware>

All images and schematics would be cited appropriately.

Please let us know if this is possible. Thank you for your time!

Very respectfully,

Knight Nite Team

14. Bibliography

[1] Chong Y., Fryar, C.D., and Gu, Q. (2013). Prescription Sleep Aid Use Among Adults: United States, 2005–2010. Hyattsville, Md.: U.S. Department of Health and Human Services, Centers for Disease Control and Prevention, National Center for Health Statistics.

[2] Colten, H. R., &Altevogt, B. M. (2006). Sleep Physiology. *Sleep disorders and sleep deprivation: An unmet public health problem*. Washington, DC: Institute of Medicine.

[3] J. Goldberg for WebMD.(2012, Oct. 6).*The Basics of Snoring*. [Online]. Available:<http://www.webmd.com/sleep-disorders/guide/snoring>

[4] Rechtschaffen, A; Kales, A (1968). A Manual of Standardized Terminology, Techniques and Scoring System For Sleep Stages of Human Subjects. US Dept of Health, Education, and Welfare; National Institutes of Health.

[5] Michael H. Silber, Sonia Ancoli-Israel, Michael H. Bonnet, et al. The visual scoring of sleep in adults. *Journal of clinical sleep medicine : JCSM*, Vol. 3, No. 2. (15 March 2007), pp. 121-131.

[6] Slow-wave sleep: beyond insomnia: The importance of slow-wave sleep for your patients Roth T & Dijk DJ (editors) Wolters Kluwer Pharma Solutions, London 2010. pp. 155.

[7] Fung, Maple M. et al. "DECREASED SLOW WAVE SLEEP INCREASES RISK OF DEVELOPING HYPERTENSION IN ELDERLY MEN." *Hypertension* 58.4 (2011): 596–603. PMC. Mon. 25 Apr. 2016.

[8] Sleepdex. *Alcohol and Sleep*. [Online]. Available: <http://www.sleepdex.org/alcohol1.htm>

[9] "Brain Basics: Understanding Sleep." *Brain Basics: Understanding Sleep*. N.p., n.d. Mon. 25 Apr. 2016.

[10] Dement, William. *The Effect of Dream Deprivation*. Washington, D.C.: American Assoc. for the Advancement of Science, 1960. Print.

[11] Voderholzer, Ulrich. "Sleep Deprivation and Antidepressant Treatment." *Dialogues in Clinical Neuroscience*. Les Laboratoires Servier, n.d. Mon. 25 Apr. 2016.

[12] Wikipedia. "Microphone." *Wikipedia*. Wikimedia Foundation, 1 Apr. 2016. Web. 15 Apr. 2016. <https://en.wikipedia.org/wiki/Microphone#Electret_condenser_microphone>.

[13] Torres, Gabriel. "How Analog-to-Digital Converter (ADC) Works - Hardware Secrets." *Hardware Secrets*. N.p., 21 Apr. 2006. Web. 28 Mar. 2016. <<http://www.hardwaresecrets.com/how-analog-to-digital-converter-adc-works/>>

[14] "Testing Methodologies." *Software*. Inflectra, 25 Aug. 2015. Web. 28 Apr. 2016. <<https://www.inflectra.com/Ideas/Topic/Testing-Methodologies.aspx>>.

[15] Manjoo, Farhad (May 27, 2015). "A Murky Road Ahead for Android, Despite Market Dominance". *The New York Times*. ISSN 0362-4331. Retrieved May 27, 2015.

[16] "Facts and Stats." Drowsy Driving Stay Alert Arrive Alive RSS. N.p., n.d. Web. 28 Apr. 2016.

[17] Smith, Aaron. "U.S. Smartphone Use in 2015."Pew Research Center Internet Science. Pew Research Center, 01 Apr. 2015. Mon. 25 Apr. 2016.